

UNIT – 1

Radio waves are electromagnetic waves that have wavelengths longer than infrared radiations. The range of radio waves is between 30 kHz and 300 GHz in an electromagnetic spectrum.

Radio waves have the best use in communication systems like television, mobile phones, radios, etc

Electromagnetic Spectrum for communication:

The transmission over the air (i.e. radio transmission) can take place using many different frequency bands. Each band has its own advantage as well as disadvantage.

The following diagram shows the frequency spectrum used for data transmission. It starts from 30 Hz and goes up to 300 THz

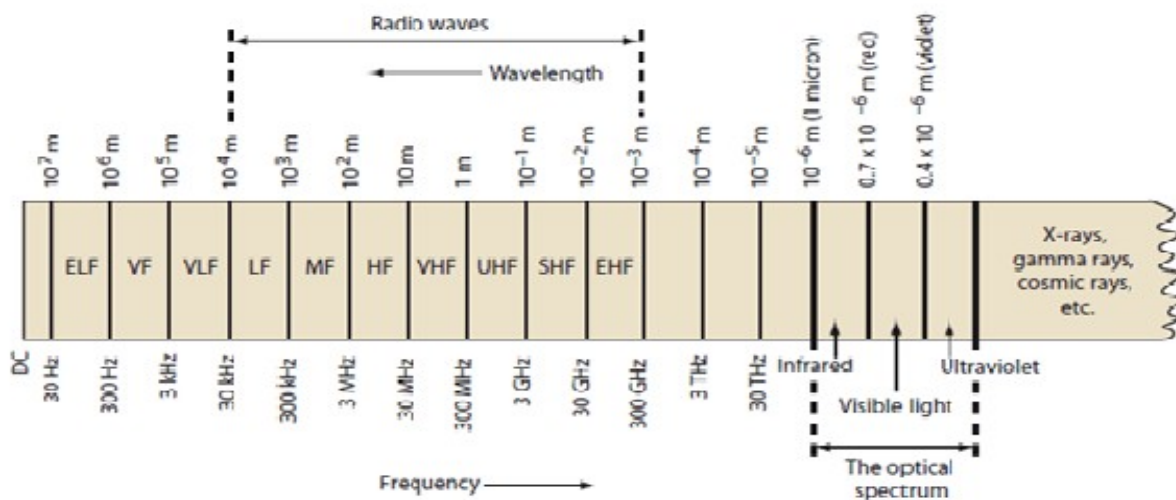

FREQUENCY	DESCRIPTION	APPLICATION
Up to 300Hz	ELF	Special communications
300Hz – 3 kHz	Voice Frequency	
3 – 30 KHz	VLF	Under water communication
30– 300 KHz	LF	AM Radio
300– 3000 KHz	MF	AM Radio
3 – 30 MHz	HF	AM Radio, long distance aviation communications,
30– 300 MHz	VHF	FM Radio, TV, Short range aviation communications
300– 3000MHz	UHF	TV. Mobile Phones, wireless networks, Blue tooth, Satellite Radio, GPS
3– 30 GHz	SHF	Satellite TV and Radio, Radar systems, Radio Astronomy
30– 300 GHz	EHF	Radio Astronomy, Full Body Scanners

Band designations & Usage - Satellite frequency bands:

Satellite technology is developing fast, and the applications for satellite technology are increasing all the time. Not only can satellites be used for radio communications, but they are also used for astronomy, weather forecasting, broadcasting, mapping and many more applications.

With the variety of satellite frequency bands that can be used, designations have been developed so that they can be referred to easily

Microwave Letter Band Designations

<i>f</i> (GHz)	Letter Band Designation
1–2	L band
2–4	S band
4–8	C band
8–12.4	X band
12.4–18	Ku band
18–26.5	K band
26.5–40	Ka band

L-band (1–2 GHz)

This band is used in

- Global Positioning System (GPS) carriers and
- Satellite mobile phones providing communications at sea, land and air; World Space satellite radio.

S-band (2–4 GHz)

This band finds applications in

- Weather radar,
- surface ship radar, and
- Some communications satellites.

C-band (4–8 GHz)

C- Band is primarily used for satellite communications. This is commonly used in areas that are subject to tropical rainfall, since it is less susceptible to rain fade.

X-band (8–12 GHz)

This is used primarily by the military also used in radar applications. X-band radar frequency sub-bands are used in civil, military and government institutions for weather monitoring, air traffic control, defence tracking and vehicle speed detection.

Ku-band (12–18 GHz)

Used for satellite communications.

Ka-band (26–40 GHz)

Communications satellites and high-resolution, close-range targeting radars on military aircraft.

Communication Systems

Communication is the process of transfer of information from sender to receiver. The following Block diagram shows a basic structure of a communication system.

Basically there are three elements in a communication system- transmitter, communication channel, and receiver.

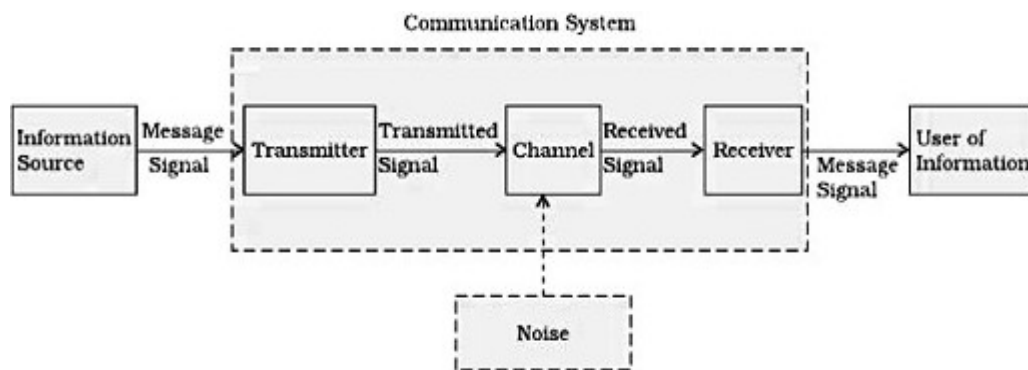

INFORMATION

It is the choice of the message out of finite set of messages. Information source originates the message.

THE TRANSMITTER:

Unless the message coming from the information source is electrical in nature, it is not possible to transmit. The transmitter converts the information coming from source into electrical form. This message is super imposed on a high frequency signal called carrier. As a result some parameter of the carrier such as amplitude, frequency or phase will change. This process is called modulation

COMMUNICATION CHANNEL

Communication channel is defined as the medium through which the signal is sent from transmitter to receiver. When signal is propagated through the channel, it gets affected by noise. And also channel attenuation degrades the signal strength, so signal power decreases with distance. In *radio communication* systems, air is the medium and in *satellite communication* systems, both air and vacuum are the medium.

RECEIVER

Signals sent through the communication channel reaches the receiver, where it is decoded or demodulated to extract the message. Since channel attenuation degrades the signal power, *amplifier* is used at the receiver to compensate for the transmission losses.

NOISE

Noise is any *unwanted signals* that interfere with the information, which includes atmospheric changes, lightning and thunderstorms, other communication systems etc. that can cause noises in the transmitted signal. Different techniques can be used to minimize the noise in the signal but it cannot be completely removed.

PROPOGATION OF WAVES:

Electromagnetic waves can be propagated in any one of the 5 methods . They can be propagated as

1. Ground (surface) waves.
2. Sky wave propagation
3. Space waves
4. Tropospheric scatter propagation
5. Stationary satellite communications.

GROUND WAVES:

Ground wave propagation is a **type of radio propagation which is also known as a surface wave**. These waves propagate over the earth's surface in low and medium frequencies.

Ground Wave propagation is a method of radio wave propagation that uses the area between the surface of the earth and the ionosphere for transmission, it. Ground wave propagation is also called surface wave propagation. The ground wave follows the contour of the earth and hence it can propagate considerable distances. Such a wave is called a **direct wave**. It exists below the 2 MHz frequency range. Ground waves are mainly used for transmission between the surface of the earth and the ionosphere.

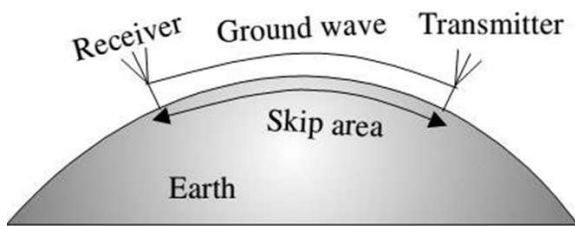

As a result of radiation from an antenna there will be electrical field strength at a distance from the antenna. The electric field strength E at a distance from an antenna through which the current I is flowing is given by

$$E = \frac{120\pi h_t h_r I}{\lambda d}$$

Where, h_t = effective height of the transmitting antenna, h_r = effective height of the receiving antenna, I = antenna current, d = distance from transmitting antenna, λ = wavelength

If the distance between the transmitting and the receiving antenna is large, the voltage that reaches the receiver is reduced because of the atmospheric and ground absorption. The intensity of these radiations drops with distance due to their absorption by ground.

SKY WAVE PROPAGATION:

Sky wave propagation also known as ionospheric propagation is mode of propagation in which electromagnetic waves emitted from antenna are directed upwards at great angles and reflected back to earth by ionosphere.

The atmosphere receives sufficient energy from the sun for its molecules to get ionized. The molecules remain ionized for a long time. There are several ionized layers at different heights. These layers reflect back to earth high frequency waves into outer space. These ionized layers are together called "IONOSPHERE". The different layers of the ionosphere have specific effects on the propagation of sky waves:

Structure of Ionosphere:

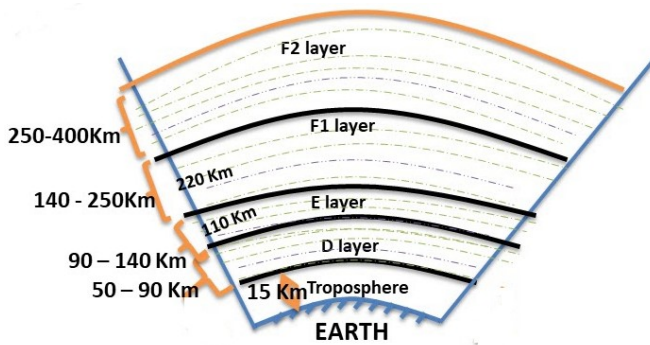

The ionosphere extends from about 60-400 kms above the earth's surface. It is divided into three regions or layers; the F-Region, E-Layer and D-Layer. During the daytime the F-Layer splits into two layers- F1 & F2 and then recombines at night.

D Layer:

This is the lowest layer existing at an average height of 70 km. its average thickness is 10 km. the degree of ionization depends on the altitude of the sun above the horizon. Hence this layer disappears at night. As far as the HF wave propagation is concerned, it is of least importance

”.

E layer:

This layer which is next to the D layer is at an average height of 100 km. its thickness is 25 km. Like the D layer, this layer also disappears at night when the solar radiation is absent. The E layer helps in MF surface wave propagation.

F1 layer:

There are two well defined semi-permanent layers. The lower of these two layers is at a height of these two layers is at a height of 90-140km. it is called “KENNELLEY HEAVISIDE LAYER”. The other layer which is at a height of 140-400 km is called “APPLETON LAYER

This layer is at a height of 180 km during day time. At night it combines with the F1 layer. During the day time its thickness is about 20 km. Some of the HF waves are reflected from the F1 layer but most of the HF waves pass through the F1 layer and are reflected by the F2 layer. Thus the main effect of F1 layer is to provide more absorption for the HF waves.

F2 layer:

This is the most important reflecting medium for high frequency radio waves. The height of this layer ranges from 250km to 400 km. Its thickness is about 200 km. At night the F2 layer descends to about 300 km and combines with F1 layer. The height and ionization density of the F2 layer is dependent on the ambient temperature and the time of the day

Reflection mechanism:

The following diagram shows the mechanism of reflection of radio waves through Ionosphere.

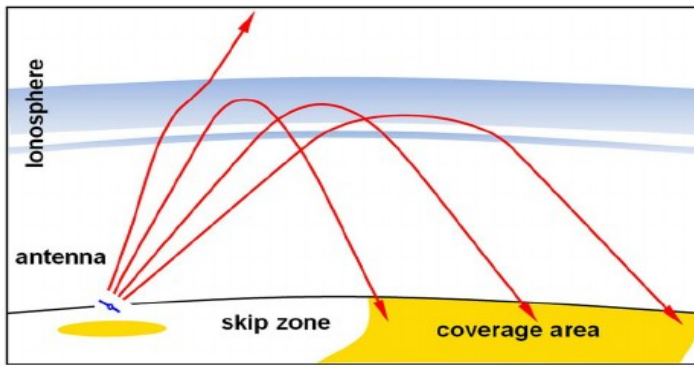

Electromagnetic waves return to earth by one of the layers of the ionosphere appears to have reflected. But the mechanism involved is refraction. As the ionization density increases at an angle, the refractive index of the layer is reduced. Hence the incident wave is gradually bent farther and farther away from normal

If the rate of change of refractive index per unit height is sufficient, the refracted ray will become parallel to the layer. It will then be bent downward, finally emerging from the ionized layer at an angle equal to the angle of incidence.

VIRTUAL HEIGHT:

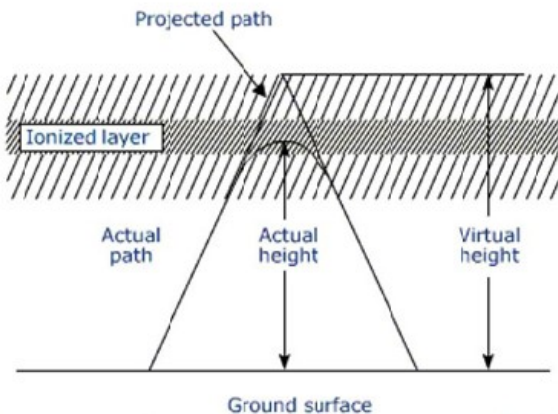

Virtual Height:

Virtual height is the effective height of a layer of ionized gas in the atmosphere by which radio waves are reflected around the earth's curvature.

CRITICAL FREQUENCY AND MAXIMUM USABLE FREQUENCY:

For a given layer the critical frequency is the highest frequency that will be returned to earth by the layer when beamed (vertically) straight up at it. The highest frequency that can returned to the earth by a layer, when it is beamed vertically”, i.e. with angle of incidence zero is termed as the critical frequency.

If θ is the angle of incidence, then the maximum value of frequency for which there will be reflection is called the “maximum usable frequency” (MUF). It is given by

$$MUF = \frac{\text{critical frequency}}{\cos\theta} = f_c \sec\theta$$

This is called SECANT LAW.

A wave can travel a considerable distance in an ionized layer in the horizontal direction. But it can be deflected by the ionized layer. Suppose the angle of incidence is kept fixed and the frequency is altered, for frequencies lower than the MUF the wave is reflected from the lower point of the ionized layer. At a frequency higher than the MUF the ray escapes into space.

SKIP DISTANCE:

The skip distance is the shortest distance from a transmitter measured along the surface of the earth, at which a sky wave of fixed frequency ($> f_c$) will be returned to earth.

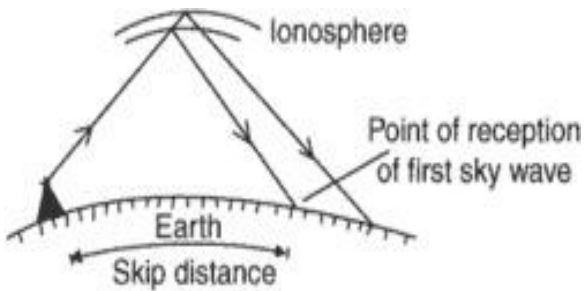

SPACE WAVES:

Space wave propagation is the type of radio wave propagation in which the radio waves are propagated either directly from transmitting antenna to receiving antenna or by reflection in the troposphere of the earth. In space wave propagation, direct transmission of the signal is achieved by line of sight communication.

Space waves travel in straight lines, since they depend on line of sight transmission.

Radio horizon:

The curvature of the earth's surface presents a horizon that limits the range of transmission. This is called the radio horizon which is larger than the optical horizon. The radio horizon of an antenna is given by

$$d_t = 4\sqrt{h_t}$$

where d_t = distance from the transmitting antenna in km and
 h_t = height of the transmitting antenna above the ground in m
Similarly for the receiving antenna

$$d_r = 4\sqrt{h_r}$$

where d_r = distance from the receiving antenna in km and
 h_r = height of the receiving antenna above the ground in m
Hence the total distance between the transmitter and receiver is given by

$$d = d_t + d_r = 4\sqrt{h_t} + 4\sqrt{h_r}$$

TRANSMISSION LINES:

A transmission line is used to transfer the energy output of the transmitter to the antenna with the minimum power loss.

There are two types of transmission lines;

- ❖ Parallel wire line (balanced)
- ❖ Co-axial line (unbalanced)

Parallel wire line:

A parallel wire transmission line consists of wires separated by a dielectric spacer commonly known as “twin lead.” The wires in twin lead line are held in place by a mechanical spacer which is a low-loss dielectric material that forms the jacket of each wire.

These lines are used at the frequencies of the order of 100MHz. The characteristic impedance of such a line is 150-600Ω.

Parallel wire line has the advantages of lower cost and lower loss.

Co-axial line:



These are suited for high frequencies. Coaxial cables have concentric layers of electrical conductors and insulating material. The centre conductor layer is a thin conducting wire of copper. A dielectric layer, made up of an insulating material surrounds the wire. A shield layer then surrounds the dielectric layer with braided copper mesh. The whole assembly is wrapped in an insulating jacket. The outer metal shield layer of the coaxial cable is grounded

There are two types of co-axial cables.

1. Flexible cables
2. Rigid cables.

Flexible cable:

In such a cable the whole inner conductor is surrounded by a flexible plastic material and a braid of conducting material wound over a dielectric. This serves as the outer conductor. Such cables are not preferred above 300 MHz, since losses in the dielectric medium become appreciable.

Rigid cables:

To avoid energy losses in the dielectric medium at HF, rigid co-axial cables are used. Rigid cables carry high power and easier to make them. This is important because all solid dielectrics have higher losses at high frequency.

Advantages:

1. Losses due to induction and radiation are reduced to minimum
2. Characteristic impedance is low of the order of 40-150 Ω .
3. Used at 300 MHz- 3000 MHz and at all frequencies because their attenuation at HF is very low.

Equivalent circuit:

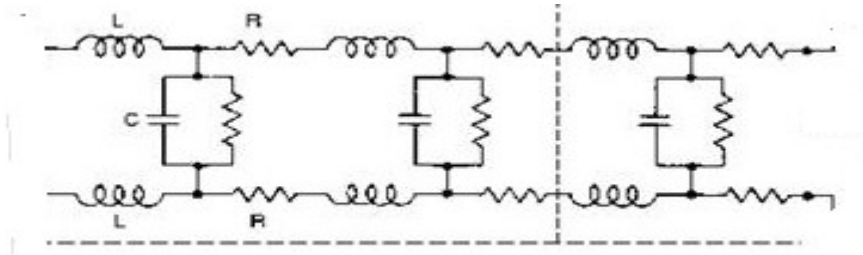

The equivalent circuit of a real transmission line is shown in **Fig**, where R, L, G, C represent resistance, inductance, conductance, and capacitance per unit length. Hence they are called “*Distributed parameters*”

The conductors of some length and diameter are present in a two wire line. Dielectrics are also present between them. If both the length and diameter are associated with the conductor then resistance and inductance are present.

If wires are separated from each other by placing the dielectric between them there will be capacitance C between them. As the dielectric is not a perfect insulator, the leakage of charge will take place. This can be explained well by introducing the concept of shunt conductance denoted by G

At RF, inductive reactance is much larger than the resistance. The capacitive reactance is also much larger the shunt conductance. Hence both R & G may be ignored compared to L & C. The resulting line is considered lossless. Hence the equivalent circuit is simplified as shown below.

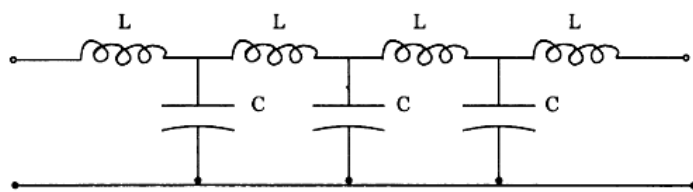

Hence the four parameters of transmission line are –

- Distributed inductance L
- Distributed resistance R
- Distributed Capacitance C
- Distributed Conductance G

Characteristic impedance:

For the transmission line, the input impedance will depend on the type of the line, its length and termination at the far end. The input impedance that is measured under standard, simple and easily reproducible conditions is taken as reference and this is called “*Characteristic Impedance*” of that line.

Let an alternating voltage be applied to the sending end of an infinite line. Then due to shunt capacitance and leakage conductance, a current will flow in the line. **The ratio of the amplitudes of voltage and current of a single wave propagating along the line** is called the characteristic impedance denoted as Z_0

Calculation of characteristic impedance:

The characteristic impedance of a line will be measured at the input when line is terminated at the far end with impedance equal to Z_0 . (Because $Z_{in} = Z_{out}$ for maximum power transfer).

If the line has infinite length, all the power fed to it will be absorbed. As we move away from the input, voltage and current will decrease along the line because of the voltage drop across the inductance and capacitance. Z_0 will be measured at the input of a transmission line if the output is terminated with Z_0 . Under these conditions, Z_0 is considered purely resistive.

It can be shown that the characteristic impedance of an iterative circuit consisting of series and shunt elements is given by

$$Z_0 = \sqrt{\frac{Z}{Y}}$$

Where $Z = R + j\omega L$ (Ω/m) is the series impedance per unit length and

$Y = G + j\omega C$ (s/m) is the shunt admittance per unit length. Hence

$$Z_0 = \sqrt{\frac{R + j\omega L}{G + j\omega C}}$$

This shows that the characteristic impedance of the transmission line is complex. At RF the resistive components are insignificant. Hence

$$Z_0 = \sqrt{\frac{L}{C}}$$

Characteristic impedance can also be determined by size, geometry, spacing of the conductors and by the dielectric constant of the insulator.

For parallel wire line

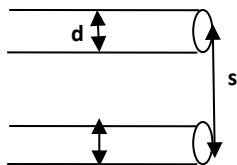

for co-axial cable

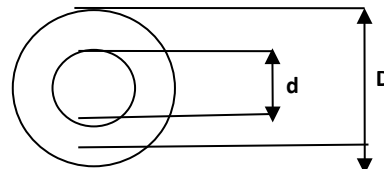

The characteristic impedance Z_0 of parallel and co-axial line is given by

For parallel wire line

$$Z_0 = 276 \log \frac{2S}{d} \quad \Omega$$

for co-axial cable

$$Z_0 = \frac{138}{\sqrt{k}} \log \frac{D}{d} \quad \Omega$$

Losses in Transmission line:

There are three ways in which energy applied to a transmission line may be dissipated before reaching the load. They are

- Radiation loss
- Conductor heating and
- Dielectric heating

Radiation loss

The transmission lines act as antennas when the separation distance between the conductors is very small as compared to their wavelength. This is observed more in parallel wire line than in co-axial line. The radiation losses increase with frequency for any given transmission line. As a result usefulness of the line at high frequency is limited.

Conductor heating

Conductor heating or power loss is proportional to characteristic impedance. Conductor heating increases with frequency because at HF, the skin effect is observed.

Dielectric heating

Dielectric heating is proportional to the voltage across the dielectric and inversely proportional to the characteristic impedance for any power transmitted. It increases with frequency because with the increase in frequency the property of dielectric deteriorates.

Velocity factor

The velocity of light and all other electromagnetic waves depends on the medium which they travel.

The velocity of light in medium is given by

$$v = \frac{V_c}{\sqrt{k}}$$

Where v = velocity in medium;

V_c = velocity in vacuum; and

k = dielectric constant.

The velocity factor of a dielectric substance is the velocity reduction ratio and is given by

$$V_f = \frac{1}{\sqrt{k}}$$

The dielectric constant of materials used in transmission line range from 1.2 to 2.8. Hence the corresponding velocity factors range from 0.9 to 0.6. Since $v = f\lambda$ and f is constant, the wave length λ is also reduced by a ratio equal to the velocity factor.

STANDING WAVES

Standing waves are waves of voltage and current which do not propagate (i.e. they are stationary), but are the result of interference between incident and reflected waves along a transmission line.

Case 1

If a lossless transmission line has an infinite length or terminated with its characteristic impedance, all the power applied to the line by the generator at one end is absorbed by the load at the other end. A line terminated with its characteristic impedance is called a **non-resonant resistive or flat line**.

If $Z_L = Z_0$, the load absorbs all power and none is reflected. The only waves then present are the voltage and current (in phase) waves travelling from generator to load.

Case 2:

When a transmission line is incorrectly terminated, the power is not absorbed by the load, but it is sent back to the generator. Hence the efficiency decreases.

Power is applied to a transmission line by a generator a voltage and current appear, whose values depend on the characteristic impedance and the applied power. The voltage and current waves travel to the load at a speed slightly less than V_c , depending on the velocity factor.

If $Z_L \neq Z_0$, some power is absorbed and the rest is reflected. Thus we have one set of Voltage and Current waves travelling towards the load and the reflected set, travelling back to the generator. These two sets of travelling waves, going in opposite directions (180° out of phase), set up an interference pattern known as “**STANDING WAVES**”.

At points separated by half wavelength from the load the voltage is zero and current is maximum. This arises because forward and reverse current waves are in phase. All these conditions will repeat at half wavelength distances, as shown in the fig.

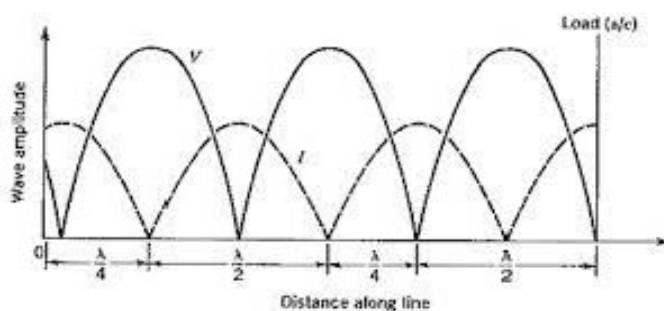

Lossless line terminated in a short circuit.

STANDING WAVE RATIO (SWR):

THE RATIO OF MAXIMUM CURRENT TO MINIMUM CURRENT ALONG A TRANSMISSION LINE IS CALLED STANDING WAVE RATIO. If the peak values of the incident and reflected voltage

waves are V_i and V_r , then maximum magnitude of the standing wave at maxima is

$$V_{\max} = V_i + V_r$$

Similarly the minimum magnitude is

$$V_{\min} = V_i - V_r$$

Then the voltage standing wave ratio (VSWR) is given by

$$\text{VSWR} = \frac{V_{\max}}{V_{\min}} = \frac{V_i + \dot{V}_r}{V_i - \dot{V}_r}$$

When the line is terminated in a purely resistive load, the standing wave ratio is given by

$$\text{SWR} = \frac{Z_0}{R_L} \vee \frac{R_L}{Z_0} \quad (\text{whichever is larger})$$

Where R_L is the load resistance.

SWR is the measure of mismatch between the load and the line. When the load is perfectly matched, the SWR is equal to unity. Higher the SWR, the greater the mismatch between line and load. If the load is purely reactive, SWR will be infinity. In practical lines, power loss increases with the SWR, and so a low value of Standing Wave Ratio is preferred.

NOISE

Noise is any unwanted signal, random or deterministic, which interferes with the faithful reproduction of the desired signal in a system.

Noise signals are classified into

- External Noise
- Internal Noise

External Noise:

External noise is defined as the type of Noise which is generated external to a communication system. .

There are three types of external noise-

- Atmospheric noise
- Industrial noise
- Extra-terrestrial noise.

Atmospheric noise:

Atmospheric Noise is also known as static noise which is the natural source of disturbance caused by lightning, discharge in thunderstorm and the natural disturbances occurring in the nature.

Industrial / Manmade Noise:

Sources of Industrial noise are - auto-mobiles, aircraft, ignition of electric motors and switching gear. The main cause of Industrial noise is High voltage wires. These noises are generally produced by the discharge present in the operations.

Extra-terrestrial Noise:

Extra-terrestrial Noise exists on the basis of their originating source. They are subdivided into

- Solar Noise
- Cosmic Noise

Solar Noise:

The sun in the solar system radiates broad range of frequencies at the temperature of about 6000 degree C. These frequencies fall within the band used for various communication purposes by the mankind. This is referred as solar noise.

Cosmic Noise:

When the directional antenna is pointed towards the sky to receive the signal, other than the desired signal it also receives random noise from the galaxy. The intensity of this noise varies very widely. This is referred as cosmic noise. The major source of this kind of noise is caused by sun ionized inter stellar gas clouds in our galaxy. There are two types of this noise viz. thermal and non-thermal. It is predominant if antenna is turned towards sky to receive the satellite signal. The cosmic noise exists from the frequency band in the range 15MHz to 100 GHz.

Internal Noise

The internal noise is generated due to active as well as passive devices used in the radio receiver and other supporting electronic circuits. This noise is randomly distributed over the entire range of frequency range used. Hence it is directly related to the bandwidth.

The internal noise is classified into –

- Thermal Noise
- Shot Noise
- Transit time noise
- Miscellaneous Noise.

Thermal noise also called as White noise or Johnson noise is generated in a resistance or any resistive component of the impedance. It is caused due to rapid and random motion of the electrons. Temperature of a particle expresses its kinetic energy. At temperature of 0 degree K, kinetic energy of particle becomes zero. Hence noise power produced in the resistor is proportional to absolute temperature and measurement bandwidth.

Shot noise is present in all the active devices including amplifiers. This is generated due to random variations in the arrival of electrons and holes at the collector terminal of the transistor.

Transit time Noise is present in transistors. This noise occurs when the time taken by an electron to travel from emitter to collector of a transistor becomes significant to the period of the signal being amplified.

Miscellaneous Noise can be categorized into Flicker Noise, Thermal (Resistance) Noise and Noise in Mixers. Resistance or Thermal noise is caused by internal resistance of emitter, base and collector.

Signal to Noise Ratio

Signal-to-noise ratio (SNR or S/N) is a measure used to compares the level of a desired signal to the level of background noise. SNR is defined as the ratio of signal power to the noise power, often expressed in decibels.

$$\frac{S}{N} = \frac{X_s}{X_n} = \frac{\frac{V_s^2}{R}}{\frac{V_n^2}{R}} = \left(\frac{V_s^2}{V_n^2} \right)$$

S = Signal Power

N – Noise Power

Noise figure and Noise factor

Noise figure and noise factor are figures of merit that indicate degradation of the signal-to-noise ratio that is caused by components in a signal chain. These figures of merit are used to evaluate the performance of an amplifier or a radio receiver.

Noise Factor is the measure of degradation of the signal to noise ratio in a device. It is the ratio of the Signal to Noise Ratio at the input to the Signal to Noise Ratio at the output. Since the signal to noise ratio at the output will always be lower than the Signal to Noise ratio at the input, the Noise Factor is always less than 1. The Lower Noise Factors results in better performance of devices. To quantify how noisy the circuit is, we define Noise Figure (NF).

$$\text{Noise Factor } (F) = \frac{\left(\frac{S_{in}}{N_{in}} \right)}{\left(\frac{S_{out}}{N_{out}} \right)}$$

UNIT – 2

MODULATION

In radio transmission, it is necessary to send audio signals over great distances. The radiation of electrical energy is practicable only at high frequencies. Hence audio signals are super imposed on high frequency signals. These high frequency signals carry the audio signals. Hence they are known as **“carrier waves” or “RF waves”**. As a result some parameter such as amplitude, frequency or phase gets altered. This process is known as **“MODULATION”** and the resultant wave is known as **“Modulated wave”**.

Hence modulation can be defined as **“the process of superimposing the low frequency signal on the high frequency carrier wave so that some parameter of the carrier wave such as Amplitude or Frequency or Phase of the carrier wave changes according to the instantaneous value of the signal”**.

NEED FOR MODULATION:

Modulation is necessary because of the following reasons-

1. Practical antenna length:

Theory shows that, in order to transmit a signal effectively, the length of the antenna should be approximately equal to the wavelength. We know that

$$\lambda = \frac{c}{f}$$

where C = velocity of light. The audio frequencies range from 20Hz to 20 KHz. Hence for an audio frequency of 20 KHz, the length of the transmitting antenna would be 15,000m, which is impracticable.

2. Operating range:

The relation between energy E and frequency ν is given by $E = h\nu$. That is energy depends on frequency. As the audio frequencies are very small, they cannot be transmitted over large distances if they are radiated directly into space.

3. Wireless communication:

One desirable feature of radio communication is that it should be carried out without wires. At AF as the efficiency of radiation is poor, it is not practicable.

Hence for the above reasons modulation is necessary in communication systems.

There are three types of modulation

- ❖ Amplitude modulation(AM)
- ❖ Frequency modulation(FM)
- ❖ Phase modulation(PM)

AMPLITUDE MODULATION:

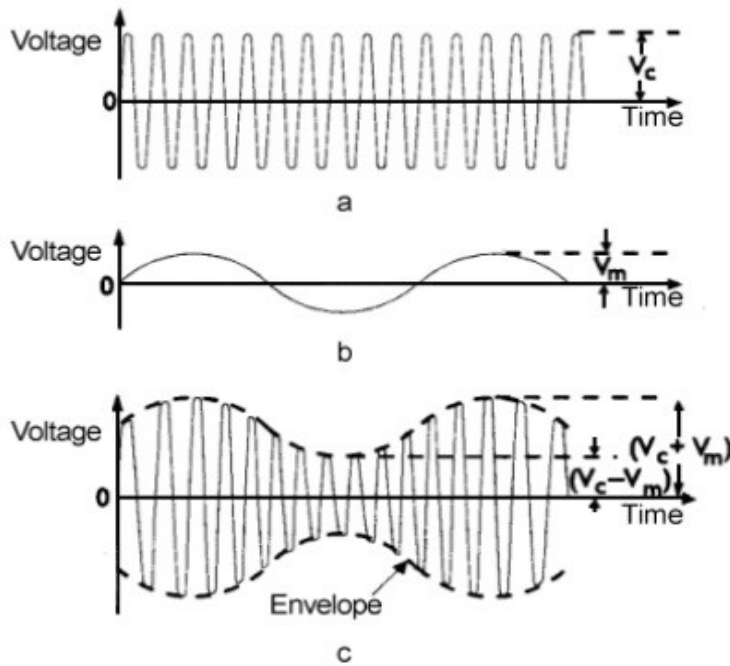

The waveforms of Amplitude modulation are as shown below

It is the process of changing the amplitude of the high frequency carrier wave in accordance with the instantaneous value of the signal, keeping other parameters constant.

Modulation factor:

Modulation factor or depth of modulation or modulation index indicates the amount of change brought about by the signal on the carrier. This is defined as **“THE RATIO OF CHANGE IN THE AMPLITUDE OF THE CARRIER WAVE TO THE AMPLITUDE OF THE NORMAL CARRIER WAVE.”** It is designated as m_a , i.e.

$$m_a = \frac{\text{Change in amplitude of the carrier wave}}{\text{Amplitude of the normal carrier wave}}$$

Modulation index can also be defined as **“THE RATIO OF THE AMPLITUDE OF THE MODULATING VOLTAGE V_m TO AMPLITUDE OF THE CARRIER VOLTAGE V_c ”**

$$m_a = \frac{V_m}{V_c}$$

EXPRESSION FOR MODULATION INDEX IN TERMS OF AM WAVE:

Consider the following fig.

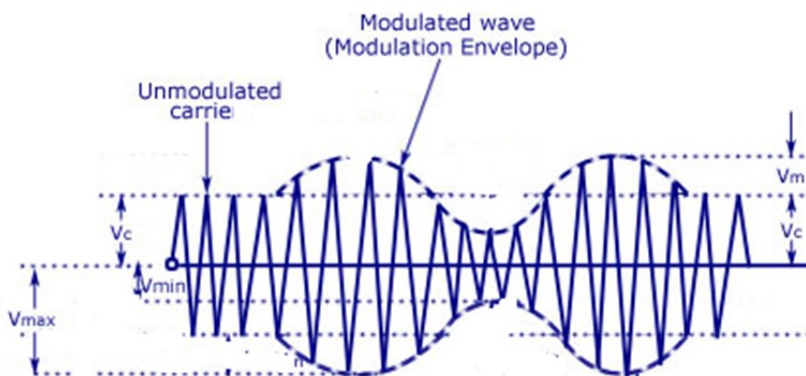

By definition, modulation index is given by the relation

$$m_a = \frac{\text{Change in amplitude of the carrier wave}}{\text{Amplitude of the normal carrier wave}}$$

From the fig, considering the maximum change, the modulation index can be written as

$$m_a = \frac{V_{max} - V_c}{V_c} \text{-----(1)}$$

Similarly considering the minimum change, the modulation index can be written as

$$m_a = \frac{V_c - V_{min}}{V_c} \text{-----(2)}$$

Adding equations (1) & (2)

$$2m_a = \frac{V_{max} - V_c}{V_c} + \frac{V_c - V_{min}}{V_c} = \frac{V_{max} - V_{min}}{V_c}$$

$$2V_c = \frac{V_{max} - V_{min}}{m_a}$$

Since the LHS of the two equations are same, the RHS is also equal. Hence equating the equations

$$\frac{V_{max} - V_c}{V_c} = \frac{V_c - V_{min}}{V_c} ; \quad V_{max} + V_{min} = 2V_c$$

Substituting for $2V_c$ from eqn (3) we get

$$V_{max} - V_{min} = \frac{V_{max} + V_{min}}{m_a}$$

$$m_a = \frac{V_{max} + V_{min}}{V_{max} - V_{min}}$$

This is the expression for modulation index in terms of AM wave

EXPRESSION FOR AM WAVES (EXPRESSION FOR INSTANTANEOUS VOLTAGE OF AM WAVE):

Consider the waveforms shown below

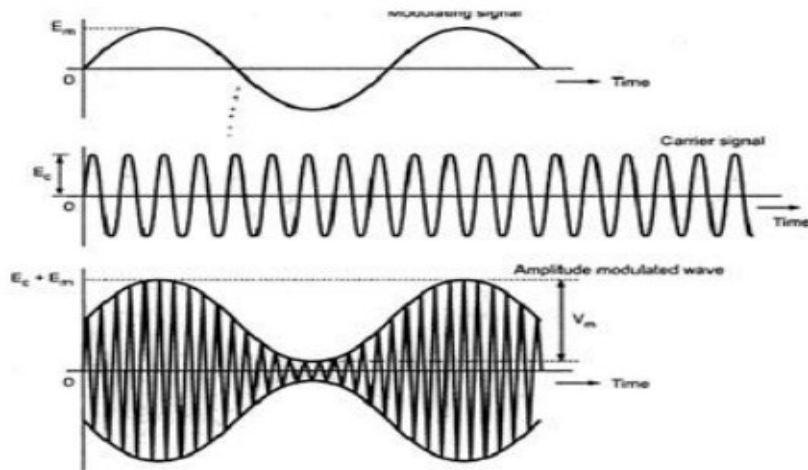

Let the instantaneous values of carrier and modulating voltage is given by

$$v_c = V_c \sin \omega_c t \text{ ----- (1)}$$

$$v_m = V_m \sin \omega_m t \text{ ----- (2)}$$

In the process of modulation, the peak value of the carrier is varied in accordance with the instantaneous value of the signal. If 'A' is the amplitude of the modulated wave, then

$$A = V_c + V_m$$

$$= V_c + V_m \sin \omega_m t = V_c \left[1 + \frac{V_m}{V_c} \sin \omega_m t \right]$$

$$= V_c [1 + m_a \sin \omega_m t]$$

Hence the expression for the amplitude modulated wave is given by

$$v = A \sin \omega_c t$$

$$= V_c [1 + m_a \sin \omega_m t] \sin \omega_c t$$

$$= V_c \sin \omega_c t + m_a (\sin \omega_c t \sin \omega_m t)$$

We know that

$$\sin A \cdot \sin B = \frac{1}{2} [\cos (A + B) - \cos (A - B)]$$

Making use of the above trigonometric relation we can write

$$v = V_c \sin \omega_c t + m_a V_c \frac{1}{2} [\cos (\omega_c - \omega_m) t - \cos (\omega_c + \omega_m) t]$$

$$v = V_c \sin \omega_c t + m_a V_c \frac{1}{2} \cos (\omega_c - \omega_m) t - m_a V_c \frac{1}{2} \cos (\omega_c + \omega_m) t$$

This is the expression for the amplitude modulated wave.

Analysis:

The following points may be noted from the above expression.

1. The AM wave is equivalent to summation of 3 sinusoidal waves – one having the amplitude V_c and frequency f_c , the second term having the amplitude $\frac{m_a V_c}{2}$ and frequency $(f_c - f_m)$, and the third term having the amplitude $\frac{m_a V_c}{2}$ and frequency $(f_c + f_m)$.
2. The AM wave contains three frequencies f_c , $(f_c - f_m)$ and $(f_c + f_m)$. i.e. in addition to the carrier frequency f_c , two more frequencies which are the sum and the difference of the carrier frequency and the signal frequency is generated. These frequencies are called “side band frequencies”. **$(f_c + f_m)$ is called the “Upper Side Band frequency” and $(f_c - f_m)$ is called the “Lower Side Band frequency”.**

Frequency spectrum and Band width:

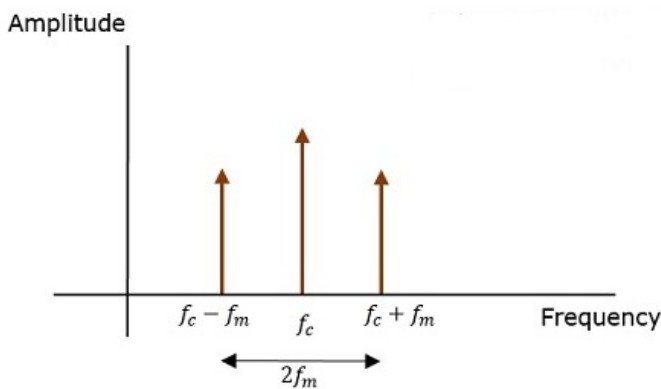

Band width:

Band width of AM wave is the useful range of frequencies over which the signal is present.

From the frequency spectrum we observe that

Band width (BW) = USB – LSB

$BW = (f_c + f_m) - (f_c - f_m) ;$

$\Delta f = 2f_m.$

Power in AM wave:

The expression for AM wave is given by

$$V = V_c \sin \omega_c t + m_a V_c \frac{1}{2} \cos(\omega_c - \omega_m)t - m_a V_c \frac{1}{2} \cos(\omega_c + \omega_m)t$$

The AM wave contains three components- carrier wave, USB and LSB. Hence the total power in the modulated wave is expressed as

$P_t = P_c + P_{USB} + P_{LSB}$ ----- (1)

But $P_c = \frac{V_c^2}{R} ; \quad P_{LSB} = \frac{m_a^2 V_c^2}{4R}$ and $P_{USB} = \frac{m_a^2 V_c^2}{4R}$

Substituting this in equation 1,

$$P_t = \frac{V_c^2}{R} + \frac{m_a^2 V_c^2}{4R} + \frac{m_a^2 V_c^2}{4R}$$

$$= \frac{V_c^2}{R} + 2 \frac{m_a^2 V_c^2}{4R} = \frac{V_c^2}{R} + \frac{m_a^2 V_c^2}{2R}$$

Where all the voltages are the peak values and R is the resistance of the antenna through which it is radiated.

Considering the RMS values of voltages and substituting this in the above equation-

$$P_t = \frac{V_c}{\sqrt{2}} + m_a^2 \left(\frac{V_c}{\sqrt{2}} \right) \frac{1}{2R}$$

$$= \frac{V_c^2}{2R} + \frac{m_a^2 V_c^2}{4R} = \frac{V_c^2}{2R} \left[1 + \frac{m_a^2}{2} \right]$$

Hence $P_t = P_c \left[1 + \frac{m_a^2}{2} \right]$

Calculation of Current:

Let I_c be the unmodulated current and I_t be the total current of the AM wave, where both currents are the RMS values of current. Let R be the antenna resistance through which the current flows. We can write

$$P_t = I_t^2 R \text{ and } P_c = I_c^2 R$$

$$\text{Also } P_t = P_c \left[1 + \frac{m_a^2}{2} \right]$$

$$\frac{P_t}{P_c} = \left[1 + \frac{m_a^2}{2} \right] ; \frac{I_t^2 R}{I_c^2 R} = \left[1 + \frac{m_a^2}{2} \right]$$

$$\frac{I_t}{I_c} = \sqrt{1 + \frac{m_a^2}{2}} \quad I_t = I_c \sqrt{1 + \frac{m_a^2}{2}}$$

Modulation by several sine waves:

If the modulation is carried out by more than one signal the modulation index is given by

$$m_t = \sqrt{m_1^2 + m_2^2 + \dots}$$

where m_t = total modulation index and

m_1, m_2 etc are individual modulation indices.

Amplitude Modulation methods – Emitter Modulator

The essential components for modulation to occur are – carrier signal and the modulating signal which is applied to a CE amplifier. The carrier signal is applied to the Base and the modulating signal is

applied to the Emitter. When the modulating signal is applied, the amplifier operates non-linearly. Because the modulating signal is applied to the Emitter, the circuit configuration is known as “**Emitter Modulator**”.

Working:

The circuit diagram of Emitter Modulator is as shown below.

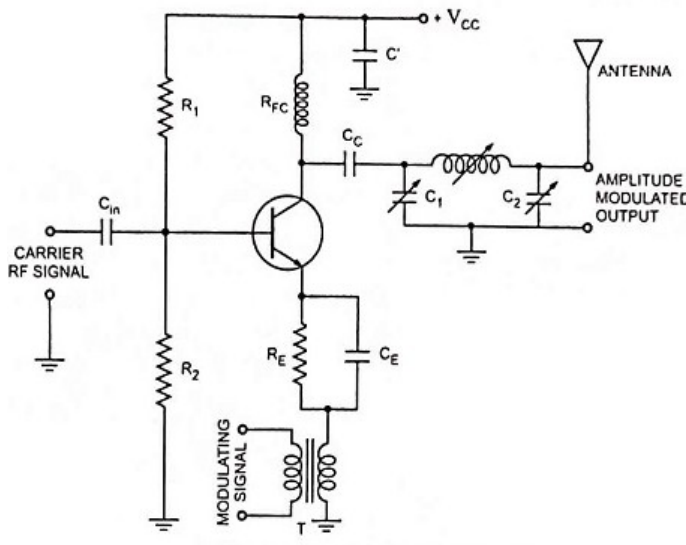

Construction and Working

The carrier signal is coupled to the base of amplifier through capacitor C_{in} . The modulating signal is applied to the emitter circuit. The capacitors C_{in} and C_C are so chosen so as to bypass carrier frequency only.

The transformer is employed to provide better matching of the impedance. The voltage divider $R_1 - R_2$ and emitter resistance R_E provide the proper biasing. The tuned circuit at the collector of the modulator stage eliminates the undesirable signals. The capacitor C' keeps the RF out of power supply V_{CC} .

The modulating signal, being a part of the biasing circuit, produces low frequency variations in the emitter circuit. The result is that the amplitude of the carrier varies in accordance with the strength of the modulating signal. The amplitude modulated output is obtained at the collector terminal of the amplifier

Disadvantages:

1. The amplifier operates in class-A region which has low efficiency.
2. It produces low output power.

Limitations of AM:

Some of the important drawbacks are-

1. Low efficiency
2. Small operating range
3. Noisy reception
4. Poor audio quality

1 Low efficiency:

From the expression of the total power, the total power is maximum when the modulation index is 1. i.e.

$$P_t = P_c \left[1 + \frac{ma^2}{2} \right]$$

i.e, 2/3rd of the total power is transmitted in contained in the carrier power. But the signal is contained in the side bands and only 1/3rd of the total power is available for the side bands. Hence it is clear that the efficiency of AM is low.

2. Small operating range:

As the efficiency is small, signals cannot be transmitted over long distances.

3. Noisy reception:

In AM the signal varies the amplitude of the carrier wave. Almost all manmade and natural noises consist of electrical amplitude variation. This influences the AM and hence the amplitude of the modulated wave will vary. When such AM waves are received, it produces noisy reception.

4. Poor audio quality:

To obtain a good audio quality, frequencies up to 15 KHz have to be reproduced. This requires a band width of 30 kHz as both side bands has to be reproduced. But AM broad casting stations are allotted with a band width of only 10 kHz. This is done in order to reduce the interference between adjacent stations. Hence the highest modulating frequency is 5 kHz. This is hardly sufficient to reproduce speech or music effectively. Hence the quality of AM transmission is poor.

SINGLE SIDE BAND TECHNIQUES

Single sideband modulation is a form of modulation in which the carrier has been cancelled out with a balanced modulator and one of the sidebands has been removed by using the filter method. SSB is made possible because in ordinary AM the carrier contains no information while the two sidebands are the mirror images of each other. From an information carrying point of view, one of the sidebands is superfluous.

The advantages of SSB -

- Requires less power to transmit
- Occupies only half of the bandwidth.

Applications -

- Mobile systems
- Point to point communications
- Land, air and maritime mobile communications
- Television
- Telemetry
- Military communication
- Radio navigation

SUPPRESSION OF CARRIER (BALANCED MODULATOR):

Carrier component is suppressed using a system called “Balanced modulator”. The circuit of Balanced modulator is as shown below. It utilizes the non-linear region of the active device-FET.

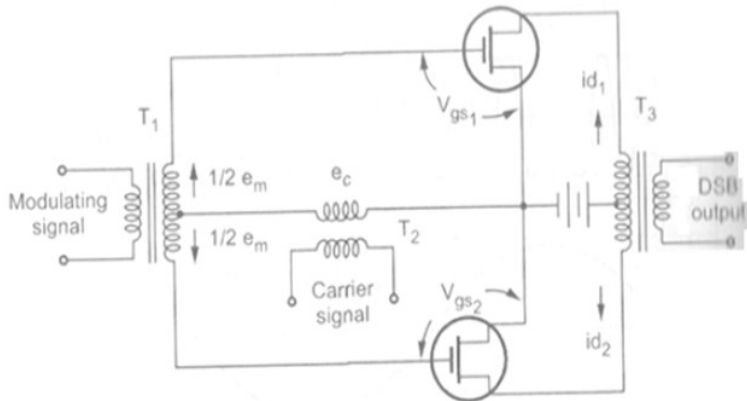

The carrier voltage is applied to the two gates of FET which are in phase. The modulating voltage appears 180° out of phase at the gates. The modulated output current of the two FETs are combined at the output of the transformer T₃. The output of the balanced modulator consists of only sidebands. The elimination of the carrier can be shown by the following mathematical analysis

Let $(V_1 + V_2)$ be the voltage at the gate of Q₁ & $(V_1 - V_2)$ be the voltage at the gate of Q₂. The relation between the gate voltage and the drain current in an FET is given by the relation

$$i = a + bv + cv^2 \text{ where } a, b \text{ \& } c \text{ are proportionality constants}$$

Hence

$$i_{d1} = a + b(V_1 + V_2) + c(V_1 + V_2)^2$$

$$= a + bV_1 + bV_2 + c(V_1)^2 + c(V_2)^2 + 2c(V_1 V_2) \text{ -----(1)}$$

Similarly

$$i_{d2} = a + b(V_1 - V_2) + c(V_1 - V_2)^2$$

$$= a + bV_1 - bV_2 + c(V_1)^2 + c(V_2)^2 - 2c(V_1 V_2) \text{ -----(2)}$$

The primary current of the output transformer is given by

$$i = i_{d1} - i_{d2}$$

$$i = a + bV_1 + bV_2 + c(V_1)^2 + c(V_2)^2 + 2c(V_1 V_2) - (a + bV_1 - bV_2 + c(V_1)^2 + c(V_2)^2 + 2c(V_1 V_2))$$

$$i = a - bV_1 + bV_2 + c(V_1)^2 + c(V_2)^2 + 2c(V_1 V_2) - a - bV_1 + bV_2 - c(V_1)^2 - c(V_2)^2 - 2c(V_1 V_2)$$

$$i = 2bV_2 + 4c(V_1 V_2)$$

But $V_1 = V_c \sin \omega_c t$ and $V_2 = V_m \sin \omega_m t$

Hence

$$i = 2bV_m \sin \omega_m t + 4c V_c \sin \omega_c t V_m \sin \omega_m t$$

$$= 2bV_m \sin \omega_m t + 4c V_c V_m \sin \omega_c t \sin \omega_m t$$

The output voltage $V_o = \alpha i$

Where α = proportionality constant. Hence

$$V_o = 2\alpha bV_m \sin \omega_m t + 4\alpha c V_c V_m \sin \omega_c t \sin \omega_m t$$

$$= 2\alpha bV_m \sin \omega_m t + 4\alpha c V_c V_m \frac{1}{2} [\cos(\omega_c - \omega_m) t - \cos(\omega_c + \omega_m) t]$$

$$= 2\alpha bV_m \sin \omega_m t + 2\alpha c V_c V_m [\cos(\omega_c - \omega_m) t - \cos(\omega_c + \omega_m) t]$$

Let $P = 2\alpha bV_m$ and $Q = 2\alpha c V_c V_m$

Hence

$$V_o = P \sin \omega_m t + Q [\cos(\omega_c - \omega_m) t - \cos(\omega_c + \omega_m) t]$$

$$= V_o = P \sin \omega_m t + Q \cos(\omega_c - \omega_m) t - Q \cos(\omega_c + \omega_m) t]$$

The above equation shows that the carrier has been cancelled out leaving only the two side bands and the modulating frequency. Thus the carrier has been suppressed

The unwanted sidebands may be removed by

- Filter method
- Phase cancellation method

THE FILTER METHOD:

This is the simplest method for sideband removal after the balanced modulator. The unwanted sideband is attenuated by a filter. The block diagram of SSB transmission employing filter system is as shown below.

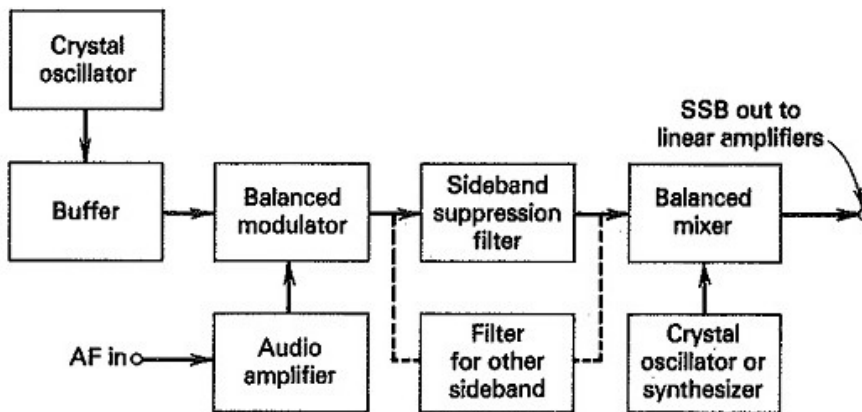

The key circuits of the transmitter are the balanced modulator and sideband suppression filter. The output of the balanced modulator is the modulating frequency, and the lower and upper sideband frequencies. To suppress one of the sidebands, side band suppression filter is used.

The maximum operating frequency of the filters is below the transmitting frequency. Hence balanced mixer is used. In this mixer, the frequency of the crystal oscillator is added to the SSB signal from the filter. Thus the frequency is raised to desired value before transmission. If the transmitting frequency is too high, then two stages of mixing is done.

The output of the balanced mixer is varying. If this signal is fed directly to subsequent stages, it would result in distortion. Hence there are fed to the linear amplifiers. Linear amplifiers are used in any AM system to reduce the signal distortion.

FREQUENCY MODULATION (FM)

In FM, the frequency of the carrier is changed while all other parameters remain the same. The FM is defined as “THE CHANGE IN THE FREQUENCY OF THE CARRIER WAVE IN ACCORDANCE WITH THE INSTANTANEOUS VALUE OF THE MODULATING SIGNAL.”

1. Frequency deviation (Δf) and carrier swing:

The amount of change in the frequency which is called the” frequency deviation The frequency of the carrier when no signal is applied is called the “resting frequency” or the “centre frequency” f_0 of the carrier. When the signal is applied, the carrier frequency deviates to maximum and minimum value from the resting frequency. This change or shift above or below the resting frequency is called **“FREQUENCY DEVIATION”** designated by Δf

The total variation of the carrier frequency from its maximum value to minimum value is called the **“CARRIER SWING”** designated as CS.

$$\text{Carrier swing CS} = 2 \times \text{frequency deviation}$$

$$CS = 2 \times \Delta f$$

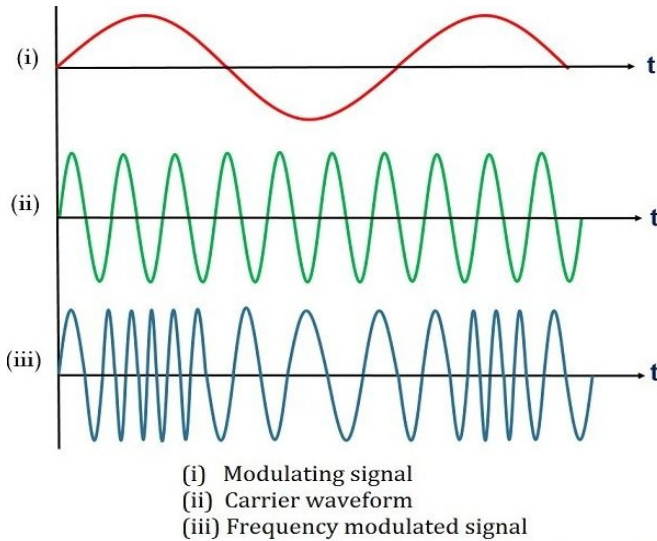

2. Modulation Index (m_f):

It is defined as “THE RATIO OF FREQUENCY DEVIATION Δf TO THE MODULATING FREQUENCY f_m .”

Modulation index =

$$\frac{\text{frequency deviation}}{\text{modulating frequency}} = \frac{\Delta f}{f_m}$$

Deviation Ratio:

It is the worst case of modulation index in which maximum permitted frequency deviation and maximum permitted audio frequencies are used.

From FM broadcasting stations, the maximum deviation is (Δf_{max}) is 75kHz maximum permitted audio frequency is ($f_{m(max)}$) 15kHz. Hence the deviation ratio is

$$\text{Deviation ratio} = \frac{(\Delta f_{max})}{f_{m(max)}} = \frac{75 \text{ kHz}}{15 \text{ kHz}} = 5$$

Percentage modulation:

It is given by the ratio of actual frequency deviation to the maximum allowed frequency deviation.

$$\text{Percentage modulation} = \% m_f = \frac{(\Delta f_{actual})}{\Delta f_{(max)}} \times 100$$

Analysis of FM wave (Expression for instantaneous voltage of FM wave)

Frequency modulation is produced when the instantaneous frequency of the carrier is varied in accordance with the modulating signal while the amplitude of the carrier remains constant.

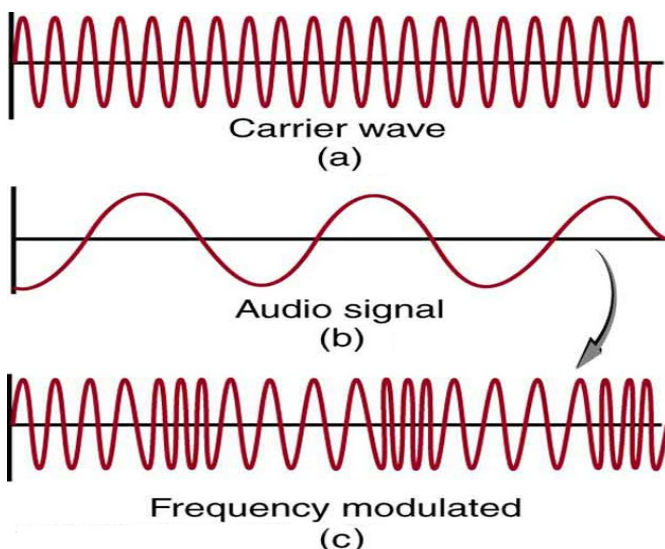

Frequency spectrum of FM wave:

Expression for FM wave is given by

$$v = V_c \sin(\omega_c t + m_f \sin \omega_m t)$$

The equation involves sine of sine function. Hence the solution involves the use of Bessel functions. On using the Bessel function, the above equation can be expanded to give

$$v = V_c [J_0(\Delta f) \sin \omega_c t + J_1(\Delta f) \{ \sin(\omega_c + \omega_m)t - \sin(\omega_c - \omega_m)t \} + J_2(\Delta f) \{ \sin(\omega_c + 2\omega_m)t + \sin(\omega_c - 2\omega_m)t \} \\ + J_3(\Delta f) \{ \sin(\omega_c + 3\omega_m)t - \sin(\omega_c - 3\omega_m)t \} + J_4(\Delta f) \{ \sin(\omega_c + 4\omega_m)t + \sin(\omega_c - 4\omega_m)t \} \\ + J_5(\Delta f) \{ \sin(\omega_c + 5\omega_m)t - \sin(\omega_c - 5\omega_m)t \} + J_6(\Delta f) \{ \sin(\omega_c + 6\omega_m)t + \sin(\omega_c - 6\omega_m)t \} + \dots]$$

OBSERVATIONS:

The mathematics of the previous discussion may be reviewed as follows-

1. FM has an infinite number of side bands, as well as carrier. They are separated from the carrier by f_m , $2 f_m$, $3f_m$, $4 f_m$, And thus have recurrence frequency of f_m .
2. The J coefficients decrease as value of n increases. Since J coefficients represent the amplitude of the particular pair of sidebands, these also decrease. The modulation index determines how many sideband components have significant amplitudes.
3. The sidebands at equal distances from f_c , have equal amplitudes, so that the sideband distribution is symmetrical about the carrier frequency.
4. The total transmitted power is always constant. But with increased depth of modulation, the required bandwidth is increased
5. The theoretical bandwidth required in FM is infinite. But in practice, the band width used is one that has been calculated to allow for all significant amplitudes of sidebands.

The frequency spectrum for $m_f = 1.5$ is as shown below.

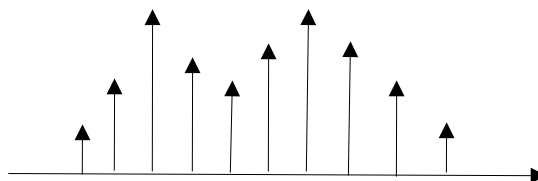

Band width:

It is defined as “THE WIDTH OF THE FREQUENCY SPECTRUM THAT CONTAINS ALL COMPONENTS HAVING AN AMPLITUDE GREATER THAN OR EQUAL TO 1% OF THE AMPLITUDE OF THE UNMODULATED WAVE.”

Suppose a given wave has n significant side band frequency pairs, then $BW = 2n f_m$.

But in practice, the approximate bandwidth is given by Carson's rule according to which

$$BW = 2(\Delta f + f_m)$$

Comparison of AM and FM

AM	FM
Amplitude of the carrier is varied in accordance with the instantaneous value of the signal	Frequency of the carrier is varied in accordance with the instantaneous value of the signal
Modulation index is the ratio of the amplitude of the carrier wave to the normal carrier wave	Modulation index is the ratio of frequency deviation to the modulation frequency
The value of modulation index is < 1	The value of the modulation index can be $<$ or > 1
There are only 2 side bands	There are several side bands
Band width is small ($= 2f_m$)	Band width is large ($= 2nf_m$)
Carrier frequency is in medium or high frequency range	Carrier frequency is VHF and UHF range
All transmitted power is not useful. Most of the transmitted power is wasted in the side band	All transmitted power is useful.
Noise suppression is not good	Noise suppression is better than AM
Efficiency is less	More efficient
Propagated as sky wave	Propagated as line of sight transmission
Area of reception is wider than FM	Area of reception is smaller than AM
Equipment is less complex and cheap	Equipment is complex and costly

PHASE MODULATION

There are two types of continuous wave modulation-

- Amplitude modulation and
- Angle modulation.

Angle modulation is sub divided into two types-

- Frequency modulation and
- Phase modulation (PM).

In PM the instantaneous phase of the carrier is varied in proportional to the instantaneous amplitude of the signal at the rate that is proportional to modulating frequency. The amplitude of

the carrier remains the same. It encodes a message signal as variations in the instantaneous phase of a carrier wave.

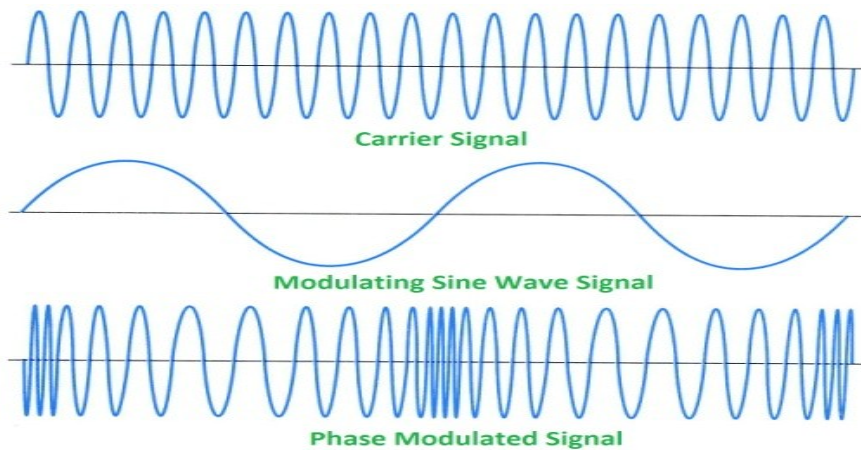

Comparison of PM and FM

PM	FM
The phase deviation is proportional to the amplitude of the signal and independent of frequency.	The frequency deviation is proportional to the amplitude of the signal
Modulation index is proportional to the modulating voltage only	Modulation index is proportional to the modulating voltage and also inversely proportional to the modulating frequency.
The PM received by FM system will have <i>bass frequencies lacking</i> .	The FM received by PM system will have signals that are <i>bass boosted</i>

Generation of FM by direct method -Varactor diode modulator

The Varactor diode FM modulator is shown below.

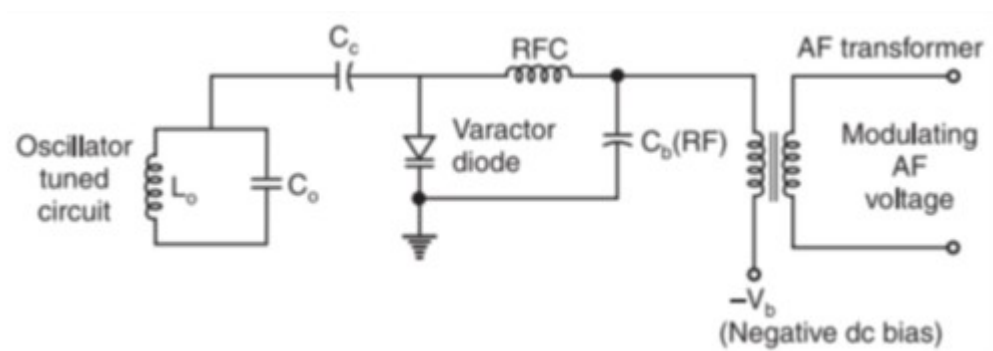

A Varactor diode is a semiconductor diode whose junction capacitance varies linearly with the applied voltage when it is reverse biased.

Working:

- The diode is reverse biased by the negative DC source – V_b .

- The modulating AF voltage appears in series with the negative supply voltage. Hence, the voltage applied across the varactor diode varies in proportion to the modulating voltage which will vary the junction capacitance of the varactor diode.
- The Varactor diode appears in parallel with the oscillator tank circuit.
- Hence the frequency of the oscillator will vary with the change in the diode capacitance and FM is produced.
- The oscillator circuit is isolated from the DC bias and modulating signal by RFC

RECEIVERS

A receiver is a device which selects the desired signal from the other unwanted signals, amplifies and demodulates it and displays the signal in the desired form.

There are two types of receivers based on the modulation process. They are

1. AM receivers
2. FM receivers

The performance of a radio receiver is determined by means of certain characteristics. They are

- Sensitivity
- Selectivity
- stability
- Fidelity and
- Signal to noise ratio

Sensitivity:

Sensitivity is the ability of the radio receiver to amplify weak signals. It is usually expressed in terms of the voltage that has to be applied to the input of the receiver to get standard output power measured at the output terminals.

Selectivity:

The selectivity of a radio receiver is the characteristic which determines the extent to which it is able to differentiate between the desired signal and unwanted signals. In other words, it is the ability to reject adjacent unwanted signals.

Stability:

It is the ability of the radio receiver to deliver a constant amount of output for a given period of time when the receiver is supplied with a signal of constant amplitude and frequency.

Fidelity:

The fidelity of a radio receiver is defined as the degree to which it accurately reproduces at the output the essential characteristics of a signal that is fed into its input.

Signal to Noise Ratio:

The signal to noise ratio is defined as the ratio of the signal power to the noise power. This ratio must be as high as possible. It is expressed in dB.

TUNED RADIO FREQUENCY (TRF) RECEIVER:

TRF receiver is the simplest form of receiver. The block diagram is as shown below.

The first RF amplifier has a tuned circuit with a variable capacitor. By adjusting the value of capacitance the internal frequency of the oscillator circuit is brought into resonance with that of delivered RF signal which is to be selected. This process is called tuning the receiver.

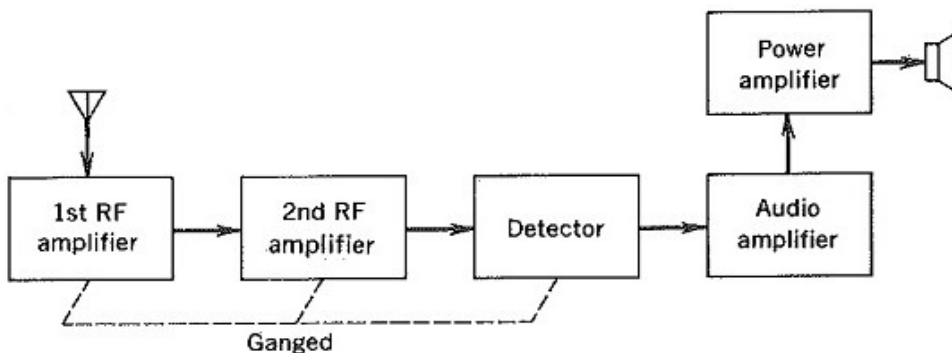

The selected RF signal is amplified. The output of the first RF amplifier becomes the input to the second RF amplifier. This stage amplifies the signal further and improves the selectivity. The amplified modulated RF goes to detector. Since all the stages will resonate with the same RF, they are connected by ganged capacitors.

Demodulator or the detector stage separates the AF signal from the RF carrier frequency and passes on only the AF to the audio amplifier. After voltage amplification the AF goes over to the power amplifier and activates the loud speaker.

Disadvantages:

1. Instability
2. Band width variation
3. Insufficient adjacent frequency rejection

These problems can be solved by the use of super heterodyne receiver.

SUPERHETERODYNE RECEIVER:

Principle:

The process of heterodyning involves the mixing of incoming signal with the output of the local so as to get the beat frequency signal. The beat frequency is equal to the difference between the local oscillator frequency and the incoming signal frequency. This beat frequency is called is “intermediate frequency”. The advantage of this process of heterodyning is that after the mixing is done all the subsequent units of the receiver has to operate at a constant frequency equal to the “Intermediate Frequency”

The block diagram of super heterodyne receiver is as shown below. The function of each block is as follows

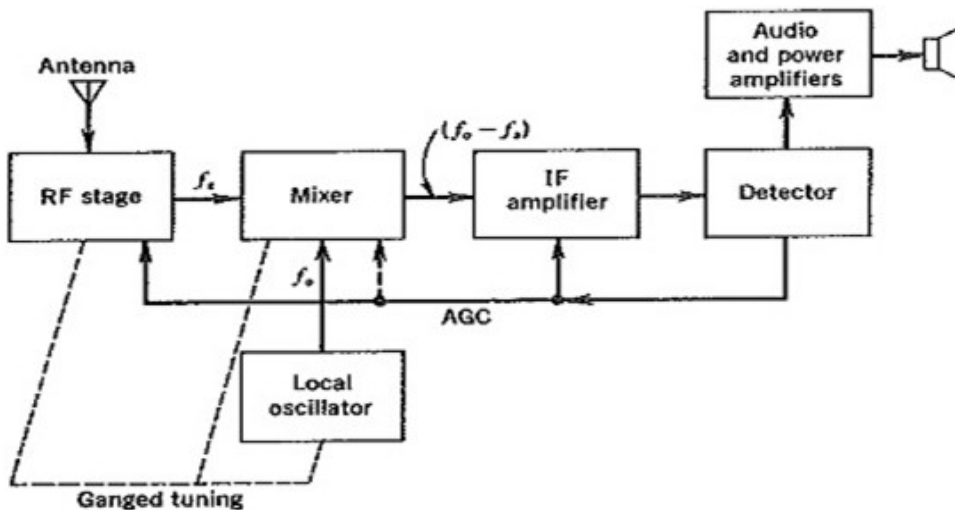

The superheterodyne receiver.

Antenna:

It intercepts the Electromagnetic waves. Voltage is induced in the antenna which is communicated to the receiver input circuit through feeder wires. A parallel tuned circuit at the input of the receiver responds only to the voltage at the desired carrier frequency and rejects voltage at all other frequencies. The voltage so produced is fed to the input of the RF amplifier stage.

RF amplifier:

This stage is generally a tuned voltage amplifier tuned to desired carrier frequency. The main function of RF amplifier is –

1. To amplify the input signal voltage to a suitably high level before feeding it to the mixer so that the signal to noise ratio is improved
2. To provide selectivity against image frequency signal and IF signal.

Frequency converter:

This consists of a local oscillator and frequency mixer. The frequency mixer is fed with local oscillator frequency f_o as well as signal frequency f_s . The mixer being a non-linear device produces at its output the various intermodulation terms. The difference in frequency voltage is picked up by the tuned circuit. This difference frequency is called the “**Intermediate frequency**”, which is 455 kHz for AM receivers. Thus with the help of frequency converter stage the RF signal of any frequency is converted into similarly modulated IF signal.

Local oscillator:

The local oscillator produces the frequency which is to be mixed with the signal frequency to produce intermediate frequency (IF). The frequency of the local oscillator is always greater than the incoming frequency

IF amplifier:

This consists of two or more stages of frequency tuned voltage amplifiers. This provides most of the receiver amplification and selectivity.

Detector:

Output of the IF amplifier stage is fed to the detector. The detector demodulates the received modulated signal, i.e., separates the carrier frequency and audio frequency. The output of the detector is the original modulating frequency. This audio frequency is fed to the AF amplifier.

AF- power amplifier:

Audio frequency output from the detector is fed to the AF amplifier which provides additional amplification. Usually one stage of audio voltage amplifier is used followed by one or more stages of audio power amplifier.

Loud speaker:

The amplified audio output voltage of the audio power amplifier is fed to a loud speaker through impedance matching transformer. The loud speaker reproduces the original sound.

Another important circuit of AM receiver is the AGC. AGC is used to maintain the constant output voltage level over a wide range of RF input signal levels. It drives the dc bias voltage from the output of the detector which is proportional to the amplitude of the received signal. This dc bias voltage is feedback to the IF and RF amplifiers to control the gain of the receiver. As a result, it provides a constant voltage level over a wide range of RF input signal levels.

FM receiver

The block diagram of FM super heterodyne receiver is as shown below.

RF amplifier:

This stage is generally a tuned voltage amplifier tuned to desired carrier frequency. The main function of RF amplifier is –

1. To amplify the input signal voltage to a suitably high level before feeding it to the mixer so that the signal to noise ratio is improved
2. To provide good selectivity

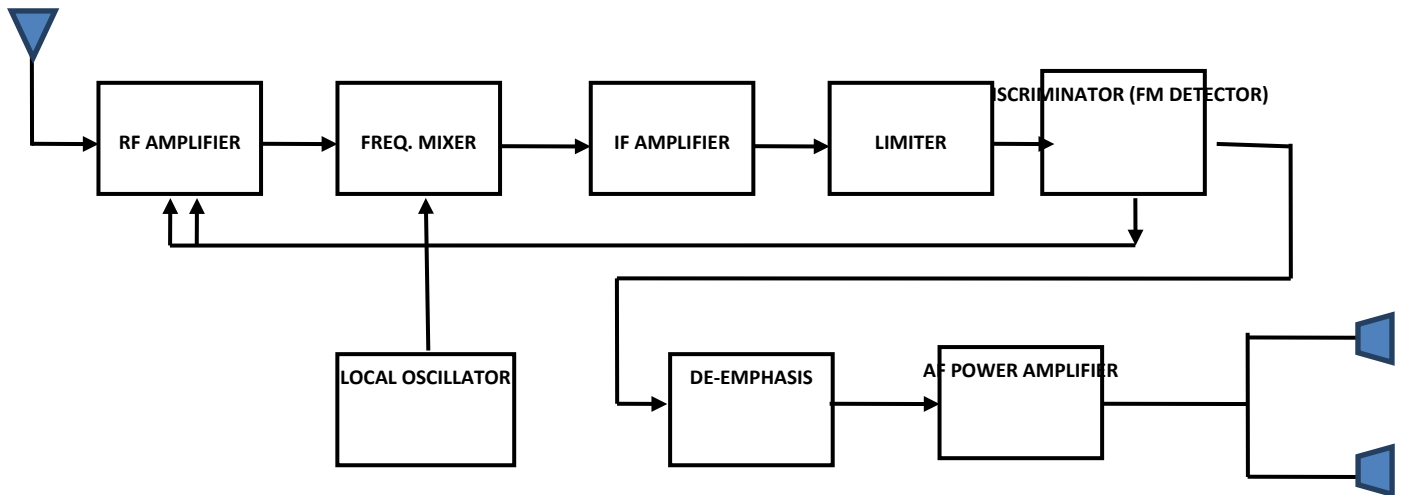

Frequency mixer:

It performs the function of mixing signal frequency voltage and local oscillator frequency voltage to provide the difference frequency voltage which is called the IF Voltage. The IF used in FM is 10.7 M Hz. Because of this large IF the image frequency rejection is good.

Local oscillator:

A separate local oscillator is used at UHF. It is preferred to keep the local oscillator frequency higher than the signal frequency by an amount equal to IF.

IF amplifier:

A multistage IF amplifiers are used to provide larger gain. Further this IF amplifier should be designed to handle large bandwidth.

Limiter:

The IF amplifier is followed by a limiter which limits the IF voltage to a predetermined level. This stage removes all amplitude variations which may be caused due to changes in the transmission path or any other disturbances.

De-emphasis:

It is found that the noise has greater effect on higher modulating frequencies than on lower ones. Hence higher AF is boosted at the transmitter to reduce the noise effect relatively. These frequencies have to be cut correspondingly at the receiver. Then the received AF output is the faithful reproduction of the modulating voltage at the transmitter. The procedure that is followed at the transmitter is called pre-emphasis and that at the receiver is called de-emphasis.

Audio amplifiers:

The output of an FM detector is fed to AF amplifiers. The output audio voltage is fed to loud speakers. Since the Bandwidth is large in FM, the loud speaker must be capable of reproducing the HF tones up to 15 kHz. Often two or more loud speakers are used each reproducing a limited range of frequencies.

Advantages:

- Broader band width accommodating wide range of IF
- Greater selectivity
- Greater suppression of noise
- High fidelity
- Suppression of image frequency interference
- Reduction of adjacent channel interference.

Disadvantages:

- Interference of weak signals
- Complicated circuitry
- Higher cost.

Difference between AM & FM receivers:

AM	FM
Carrier frequency range is in medium or high frequency range	Carrier frequency range is in VHF or UHF range
Band width is small	Band width is large
IF is 455 kHz	IF is 10.7 M Hz
RF amplifier does not contain limiter stages	RF amplifier may contain one or more limiter stages
No frequency sensitive device is used.	Frequency sensitive device is used in place of AM detector
De-emphasis circuit is not used	De-emphasis circuit is employed with audio circuit to remove the pre-emphasis inserted at the transmitter

DETECTION:

Demodulation or detection is the process of extracting the audio signal from the modulated carrier wave. In other words, the detection is the process of separating the AF and RF component of the modulated wave.

The process of detection of AM wave involves two operations;

1. Rectification of the modulated wave
2. Elimination of the carrier component of the modulated wave.

Diode detector:

The circuit of diode detector is as shown below.

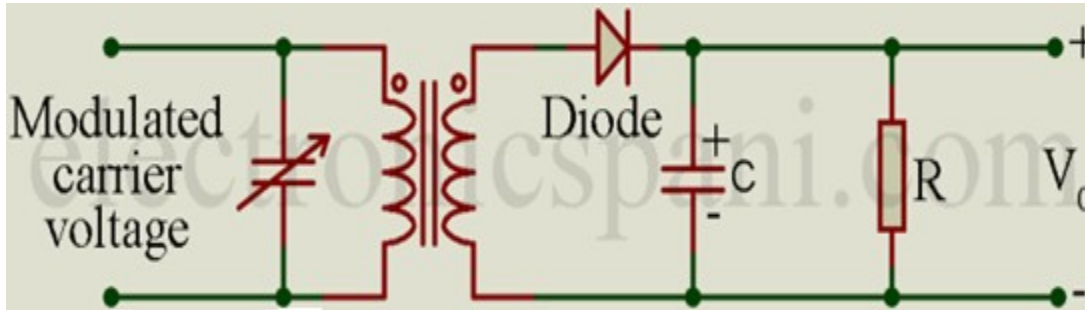

The RC combination forms the load resistance across which the rectified output voltage V_0 is developed.

Operation:

The modulated input is fed to the input of the detector. The diode in the detector rectifies the modulated input signal voltage. The rectified signal is then passed on to the low pass filter circuit RC. At each positive peak of the RF cycle, C charges up to maximum potential V_s . During the negative half cycle, as the diode is non-conducting, the capacitor begins to discharge through R. Since R is a very large value, only little charges decay through it. This leakage of charge is replenished at the next positive peak. The result is, the voltage V_0 which reproduces the modulating voltage accurately except for small amount of RF ripple. The time constant RC must be small enough to keep the RF ripple as small as possible.

Disadvantages:

This has the disadvantage that V_0 in addition to being proportional to the modulating voltage, also has the DC component which represents the envelop amplitude and a small RF ripple. The unwanted component s are removed in a practical diode detector.

FM Detector (Slope detector)

In frequency demodulation or detection, the original modulating signal is recovered from the FM wave.

1. First, an output signal having amplitude which is directly proportional to the instantaneous frequency of FM wave is obtained.
2. The output signal obtained is then detected using diode detector.

Slope detector:

Slope detection is the very simplest form of FM demodulation. The circuit and characteristic curve is as shown below

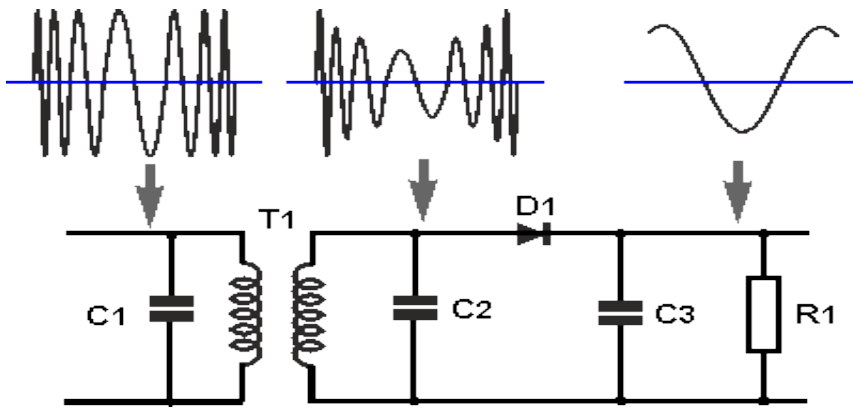

An FM slope detector consists of a tuned circuit where the centre frequency lies in the midway of one side of the characteristics curve.

As the frequency of the signal varies according to its modulation, the amplitude of the signal also varies according to the frequency variations. Therefore, frequency variations in the input signal produce proportional output voltage variations.

The final stage in the process is to demodulate the amplitude modulation. The output voltage is applied to the diode detector with an RC load of suitable time constant to get the original modulating signal.

Advantages:

- **Simple - can be used to provide FM demodulation when only an AM detector is present.**
- **Enables FM to be detected without any additional circuitry.**

Disadvantages:

- **Not linear as the output is dependent upon the curve of a filter.**
- **The signal cannot be received at its maximum signal strength.**

UNIT III

Antennas:

The output of the transmitter has to be fed into the space at the transmitting station. In a similar way the receiver has to be coupled to the space. For this some kind of interface is necessary. Antenna is such a device.

An antenna is a metallic structure, used to convert the high frequency current into electromagnetic waves and vice versa.

Antennas can be classified as –

- Resonant Antenna and
- Non-resonant Antennas.

In resonant antenna, the pattern of the current is in the form of standing wave. E.g. T V antenna.

In non-resonant antenna, the current is in travelling wave pattern. They are used in short wave communication.

The difference between resonant antenna and non-resonant antenna is as follows.

Resonant Antenna	Non-Resonant Antenna
Resonant antennas are bi-directional	Non-resonant antennas are uni-directional
In resonant antennas both forward and reflected waves exist	In non-resonant antennas only forward waves exist

Radiation Patterns Of Resonant Antennas:

The radiation pattern of a resonant antenna depends on its length relative to the wavelength. The radiation pattern of resonant antennas of various lengths is as shown below.

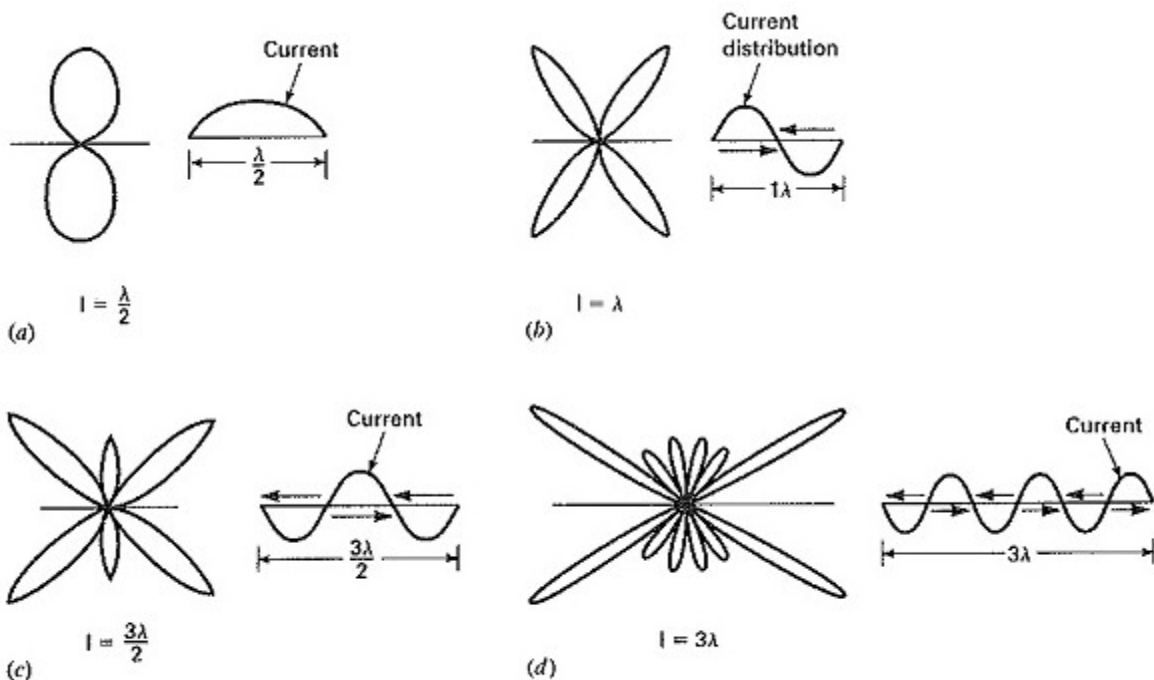

Radiation patterns of various resonant dipoles.

The length of the antenna can be calculated using the relation

$$L = \frac{\text{velocity}}{f} \times \text{vel. factor}$$

The half wave antenna has distributed capacitance and inductance and hence acts like a resonant circuit. The voltage and current will not be in phase.

When the length of the antenna is one complete wave length, the polarity of the current in one-half of the antenna is opposite to that on the other half. As a result of these out of phase currents, the radiation at right angles from this antenna will be zero. The direction of maximum radiation is at 54° to the antenna and there are four lobes.

When the length of the antenna is $3/2\lambda$, from one end of the antenna adds to that from the other at right angles. But both are partially cancelled by the radiation from the center which carries a current of opposite polarity. There is radiation at right angles to antenna, but it is not reinforced. Hence minor lobes exist in this direction. The direction of major lobes is closer to the direction of antenna.

If the length of antenna is 3λ , the direction of major lobes is closer and more aligned in the direction of the antenna.

Non –resonant antenna (Directional antennas):

A non-resonant antenna does not produce any standing wave. It is terminated by the proper load so that no standing waves exist. It is unidirectional. The radiation pattern of non-resonant antenna is as shown below.

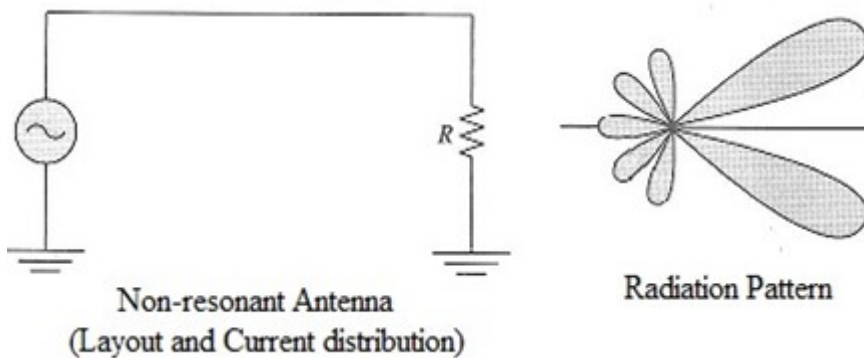

Non-resonant antennas or traveling wave antennas are configurations of antennas whose voltage and current can be represented as one or two traveling waves moving in the same direction.

In non-resonant antennas, the waves travel in the forward direction is called unidirectional traveling wave antennas. As the radiated waves are moving in the same direction, there is only an incident wave in and there is no reflected wave. Moreover, the wave patterns in non-resonant antennas fail to form standing wave patterns.

Antenna gain:

Antenna Gain describes **how much power is transmitted in the direction of peak radiation to that of an isotropic source**. Antenna gain is the ability of the antenna to radiate in any direction compared to a isotropic antenna. If an antenna could be made as a perfect sphere, it would radiate equally in all directions. Such an antenna is theoretically called an isotropic antenna

Directive gain:

Directive gain is defined as the ratio of the power density in a particular direction of one antenna to the power density that would be radiated by an omni directional antenna. The power density of both types of antenna is measured at a specific distance and a comparative ratio is established.

Example:

The gain of the hertzian antenna with respect to isotropic antenna = 1.5: 1

The gain of the half-wave dipole antenna with respect to isotropic antenna = 1.64: 1

Directivity:

Directivity of an antenna is defined as the ratio of the radiation intensity in a given direction from the antenna to the radiation intensity averaged over all directions.

Power gain of an antenna is defined as the ratio of the output power of an antenna in a certain direction to that of an isotropic antenna. This is expressed mathematically as

$$A \text{ (dB)} = 10 \log_{10} \left(\frac{P_2}{P_1} \right)$$

Where A = antenna gain in dB,

P₁ = power of unidirectional antenna

P₂ = power of isotropic antenna

Effective radiated power:

This describes the performance of a transmitting system. It applies to the field gain of the antenna and efficiency of the transmitter.

$$E_{rp} = P_0 \times (\text{field gain})^2$$

Field Intensity:

The field strength (field intensity) of an antenna's radiation at a given point in space is equal to the amount of voltage induced in a wire antenna 1m long, located at that given point.

Antenna Resistance:

Radiation resistance(R) is the ratio of the power radiated (P) by the antenna to the square of the current (I) at the feed point. Mathematically

$$R = \frac{P}{I^2}$$

Antenna efficiency:

Antenna Efficiency is the ratio of the output power radiated of the antenna to the input power accepted by the antenna.

All the input power given to the antenna will not radiated into the space. There will be some losses. If P_{in} is the total input power delivered to the feed point, P_d is the power lost and P_{rad} is the power actually radiated, then

$$P_{in} = P_d + P_{rad}$$

$$I^2 R_{in} = I^2 R_d + I^2 R_{rad}$$

$$R_{in} = R_d + R_{rad}$$

where R_d = antenna resistance and R_{rad} = antenna radiation resistance

$$\text{Antenna efficiency } \eta = \frac{\text{output power radiated}}{\text{total input power}}$$

$$\eta = \frac{R_{rad}}{R_{rad} + R_d}$$

ANTENNA PARAMETERS - BAND WIDTH, BEAM WIDTH & POLARIZATION:

Band width, beam width and polarization are the important parameters of an antenna.

Band width:

The bandwidth of an antenna refers to the range of frequencies over which the antenna can operate correctly. Over this range antenna will radiate satisfactorily. When the antenna power drops to (3 dB), the upper and lower cutoff frequencies are obtained.

Beam width:

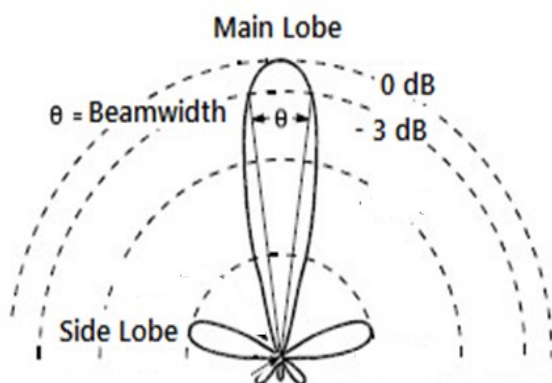

The beam width of an antenna is the angular separation between two half power points (3dB) on the power density radiation pattern. **Beam width is defined as the angle within which the intensity is not less than one- half the intensity on the beam axis.**

Polarization:

Polarization refers to the direction of the electric vector in the radiated electromagnetic wave. It is parallel to the antenna itself. Hence if the electric vector is in the vertical direction, the antennas as are referred to as vertical antennas. If the electric vector is in the horizontal direction, the antennas as are referred to as horizontal antennas.

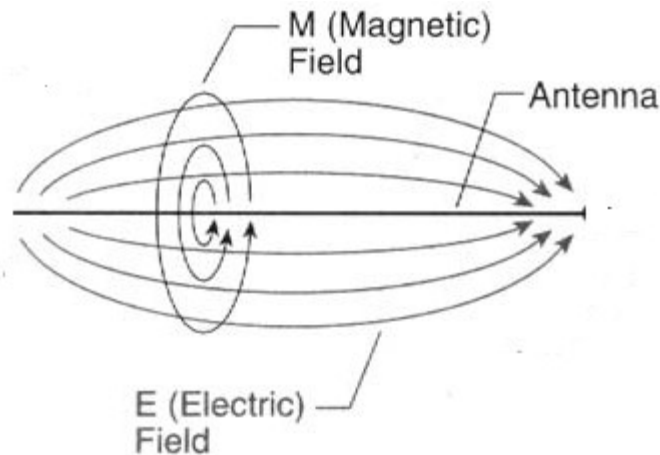

UHF and microwave antennas:

The UHF (0.3-3G Hz) and microwave (1-100G Hz) transmitting and receiving antennas are highly directional antennas. Parabolic antenna is one such antenna

Antennas with parabolic reflectors:

The parabola is a plane curve, defined as the locus of a point which moves so that its distance from another point called the “**focus**” + its distance from the straight liner called “**directrix**” is constant.

Geometry of the parabola:

Consider the parabola CAD as shown in the fig. F is the focus and AB is the axis of the parabola. From the definition of the parabola, we can write $FP + PP' = FQ + QQ' = FR + RR' = k$

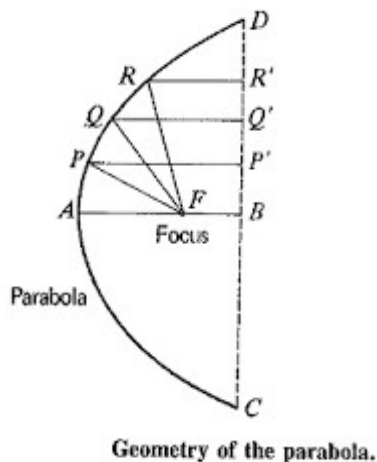

K = constant and AF = focal length of the parabola.

The ratio of the focal length to mouth diameter (AF/CD) is called the **aperture** of the parabola.

Consider a source of radiation placed at focus. All waves coming from the source and reflected by the parabola will have travelled the same distance by the time they reach the directrix, irrespective of the point of reflection on the parabola. All such waves are in phase.

As a result the radiation is very strong and concentrated along the AB axis. Thus a parabola produces concentrated beams of radiation. This property of the parabola is used in developing the parabolic reflector

A parabolic reflector or paraboloid is a bowl shaped surface obtained by revolving the parabola about the axis AB. **It is a high gain receiving directional antenna reflector.** The reflector is directional because only the rays arriving from the BA direction are brought together at the focus. On

the other hand, rays from any other direction are cancelled at that point, owing to path differences. The reflector provides a high gain because it acts like a mirror.

Properties of paraboloid reflectors:

The directional pattern of an antenna using a parabolic reflector has a very sharp main lobe surrounded by number of minor lobes, which are much smaller. The paraboloid will produce a beam of radiation whose width is

$$\varnothing = \frac{70 \lambda}{D} \text{ And } \varnothing_0 = 2\varnothing$$

Where \varnothing = beam width between half power points

\varnothing_0 = beam width between nulls and

D = mouth diameter

The gain of the antenna using paraboloid reflector is influenced by the aperture ratio (D/λ) and uniformity of the illumination. For a loss less antenna, the power gain is given by

$$A_p = 6 \left(\frac{D}{\lambda}\right)^2$$

Feed mechanisms:

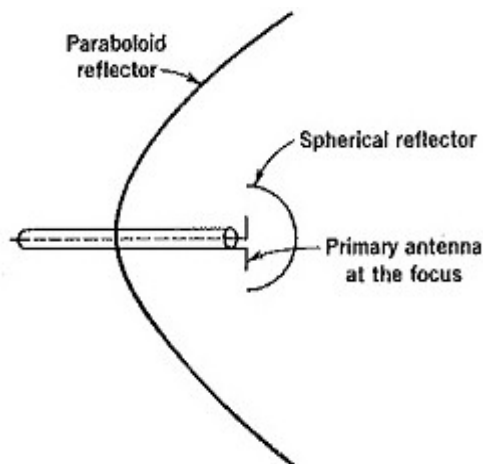

The primary Antenna is placed at the focus of the paraboloid for best results in transmission or reception. The direct radiation from the feed, which is not reflected by the paraboloid, tends to spread out in all directions and hence partially spoils the directivity. Several methods are used to prevent this, one of them being the provision of a small spherical reflector, as shown in Figure, to redirect all such radiation back to the naraboloid.

SATELLITE COMMUNICATIONS

Satellite communications is the use of satellite technology in the field of long distance communications. This is used in communications of voice and video calling, internet, fax, television and radio channels.

Need for satellite communication:

1. Satellite communication adds capacity to the already existing communication system capabilities
2. The Satellite Communication provides alternate routing for communication traffic.
3. The satellite communication remains operative even when other systems are inoperable.
4. This satellite communication provides significant contribution to improved reliability of Navy communications.
5. It is capable of handling thousands of communication channels.
6. Communication satellite frequencies are not dependent on reflection and refraction and are only affected by atmospheric phenomenon.

Hence they find applications in

- Weather Forecasting
- Radio and TV Broadcast
- Military Satellites
- Navigation Satellites
- Global Telephone
- Connecting Remote Areas
- Global Mobile Communication

Orbit:

Satellites travel round the Earth along predetermined trajectory. This trajectory of the satellite is called Orbit.

Orbital parameters:

The orbital parameters are-

- Apogee
- Perigee
- Ascending Node:
- Descending node:
- Semi major axis;
- Eccentricity

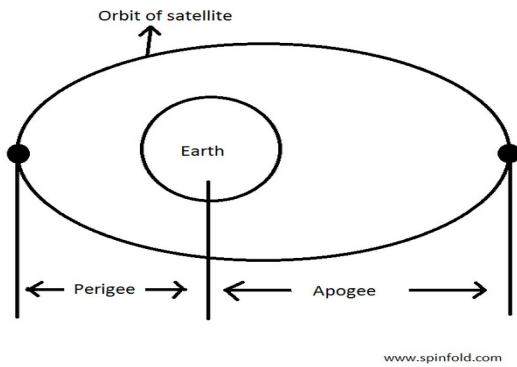

Apogee:

Apogee is the point on the satellite orbit that is the farthest distance from the centre of the earth.

Perigee:

Perigee is the point on the satellite orbit that is the farthest distance from the centre of the earth

Ascending Node:

The point at which satellite intersects the equatorial plane while going from south to north.

Descending node:

The point at which satellite intersects the equatorial plane going from north to south.

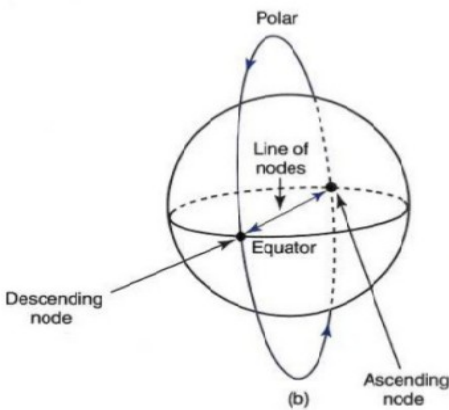

Semi major axis;

It is a geometrical parameter of an elliptical orbit. It is given by

$$a = \frac{A + P}{2}$$

where A = Apogee & P = Perigee

Eccentricity

The eccentricity e is a measure of the ‘circularity’ of the orbit. The orbit “**Eccentricity e is the ratio of the distance between the centre of the ellipse and the centre of the earth to the semi-major axis of the ellipse.**” It can be computed from any of the following expressions.

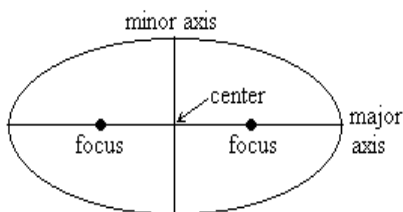

$$e = \frac{A - P}{A + P}$$

$$e = \frac{A - P}{2a}$$

$$\sqrt{a^2 - b^2}$$

Where a = semi major axis and b = semi minor axis. A = Apogee & P = Perigee.

(Problems)

Kepler's Laws

1. Kepler's First law:

Kepler's first law states that "the satellite will orbit round the earth in an elliptical orbit with earth at one of its foci."

2. Kepler's second law:

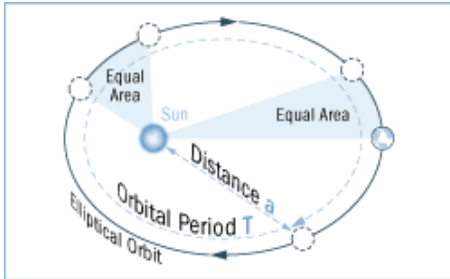

The satellite revolves around the earth in such a way that the line joining the satellite to the earth sweeps over equal areas in equal intervals of time.

3. Kepler's third law:

The cube of the mean distance (a) of a Satellite from the Earth is directly proportional to the square of time (T) it takes to move around the Earth.

$$\text{i.e., } T^2 \propto a^3$$

Types of satellite Orbits:

The angle between the orbital plane of the satellite and the equatorial plane of the Earth is called "**Angle of Inclination**". The satellite orbits can be classified on the basis of-

1. Orientation of the orbital plane
2. Eccentricity
3. Distance from the Earth.

1. Orientation of the orbital plane:

Depending on the orientation of the satellite with respect to equatorial plane of the earth, the orbits can be classified as

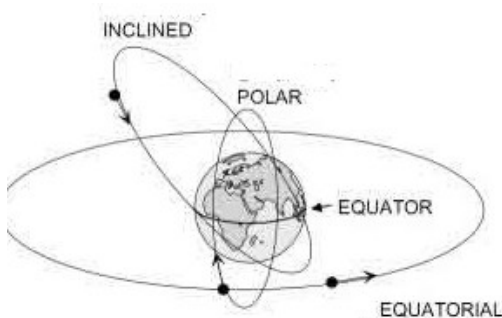

1. Equatorial orbit
2. Polar orbit
3. Inclined orbit

In Equatorial orbit the angle of inclination is zero. i.e., the orbital plane of the satellite coincides with the Earth's equatorial plane.

An orbit that passes above or nearly above both poles of the Earth on each revolution is called **Polar Orbit**. In this case, the angle of inclination is 90° .

In **inclined orbit**, the angle of inclination is between 0° & 180° .

For an angle of inclination between 0° & 90° , the satellite orbits in the same direction as the direction of the earth. The orbit in this case is referred to as “**Prograde Orbit**”.

For an angle of inclination between 90° & 180° , the satellite orbits in the opposite to the direction rotation of the earth. The orbit in this case is referred to as “**Retrograde Orbit**”.

2. Depending on Eccentricity:

On the basis of eccentricity, the orbits are classified as Elliptical and Circular Orbits.

When the eccentricity of the orbit is between 0 & 1, the orbit is said to be **elliptical**. If the eccentricity is zero, the orbit is said to be **circular**.

3. Depending on the distance from the Earth:

Depending upon the distance between satellite and the earth, these are classified as

1. Low earth orbits (LEO)
2. Medium earth orbits (MEO)
3. Geostationary earth orbits (GEO)

Low earth orbits (LEO):

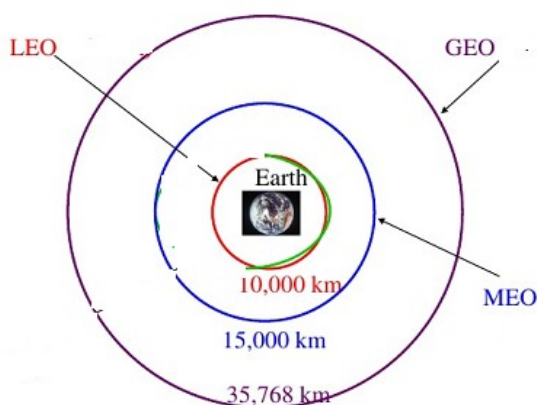

LEO satellites circle earth around 160 - 500 km above the surface of the earth. As these satellites are closer to earth, they have shorter orbital periods and smaller propagation delays. Due to lower propagation paths, the power required for transmission is less. But because of shorter orbital periods these satellites remain over a particular ground station for a short time. Hence more number of satellites is needed for 24 hour coverage.

Medium earth orbits (MEO):

MEO satellites orbit the earth at a distance of approximately 10000 km – 20000 km above the surface of the Earth. The orbital period of these satellites is 6 to 12 hrs. These satellites stay in sight over a particular region of Earth for a longer time. The transmission distance and propagation delays are greater than those for LEO satellites. These orbits are polar in nature and used particularly for communication and navigation applications.

Geostationary earth orbits (GEO):

The orbital velocity of GEO satellites is such that it is equal to speed of Earth's rotation. If such an orbit were in the plane of the equator and circular, it would remain stationary with respect to given point on the Earth. These orbits are referred to as “**Geostationary Earth Orbits**”. **This is also called**

Geosynchronous Earth orbit. For the satellite to have such an orbital velocity it has to be placed at a height of about of 36000 km above the surface of the Earth.

Geostationary Orbit:

A geostationary orbit is a particular type of geosynchronous orbit, which has an orbital period equal to Earth's rotational period. A GEOSTATIONARY SATELLITE is one that appears to be stationary relative to the earth.

For a satellite to be in geostationary orbit it has to fulfil the following requirements;

- The satellite should have 0° latitude.
- The angle of inclination should be zero.
- The orbital period should be equal to orbital period of the Earth.

The satellite should orbit at a height of approximately 36000kms

Calculation of the height of the geostationary orbit:

Gravitational force of the earth = $6.67 \times 10^{-11} \text{ nm}^2/\text{kgm}^2$

Mass of the Earth = $5.972 \times 10^{24} \text{ kg}$

Radius of the Earth = 6371 km

The gravitational; force of the earth causes the satellite to go in orbit. Hence gravity is the cause for centripetal force.

For circular motion of a planet, the condition is that:

F (Gravitational) = F (centripetal)

$$\frac{GMm}{(R+d)^2} = \frac{mv^2}{(R+d)}$$

Where M = Mass of the Earth; m = Mass of the satellite; d = Distance from the surface of the earth to satellite; R = radius of the Earth.

$$\Rightarrow (R + d) = \frac{GM}{v^2}$$

We know that the velocity v of the satellite in its orbit is equal to the circumference of the orbit divided by the time required for one revolution T. So

$$V = \frac{2\pi(R+d)}{T}$$

where T = period of revolution of the satellite which is equal to 24 Hrs = 24 X 60 X 60.

Substituting for v the above equation becomes

$$\Rightarrow (R + d) = \frac{GM \times T^2}{4\pi^2 (R+d)^2}$$

$$\Rightarrow (R + d)^3 = \frac{GM \times T^2}{4\pi^2}$$

Substituting for the constants

$$\Rightarrow = \frac{6.67 \times 10^{-11} \times 5.972 \times 10^{24} \times (24 \times 60 \times 60)^2}{4\pi^2}$$

$$\Rightarrow (R + d)^3 = 7.332 \times 10^{22}$$

$\Rightarrow (R + d) = 42,231.6$ km. If the radius of the Earth = 6371 km, then

$$d = 42231 - 6371 = 35,860 \text{ Kms.}$$

Hence the height of the geostationary orbit from the surface of the Earth is 35,860 Kms.

Advantages & disadvantages of geostationary satellites:

Advantages	Disadvantages
<ul style="list-style-type: none"> • Satellite always in same position relative to earth - antennas do not need re-orientation • These satellites have revolutionized global communications, television broadcasting and weather forecasting, and have a number of important defence and intelligence applications. 	<ul style="list-style-type: none"> • Long path length, and hence losses when compared to LEO, or MEO. • Satellites more costly to install in GEO in view of greater altitude. • Long path length introduces delays. • Geostationary satellite orbits can only be above the equator and therefore Polar Regions cannot be covered.

Attitude control:

ATTITUDE means satellite's direction in space. Attitude control is necessary

1. To keep the directional antennas aboard the satellite pointing to the desired regions of the earth. The antennas will also have specific footprints to maximize the coverage of certain areas.
2. To maintain proper orientation and positioning of the foot-print.

A satellite's attitude can be altered along one or more of three axis called ROLL, PITCH & YAW.

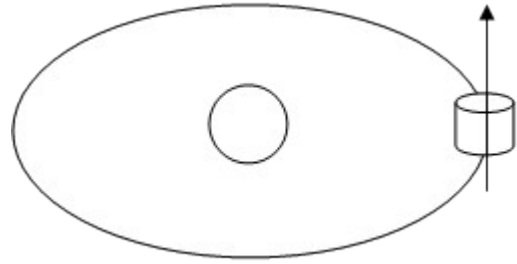
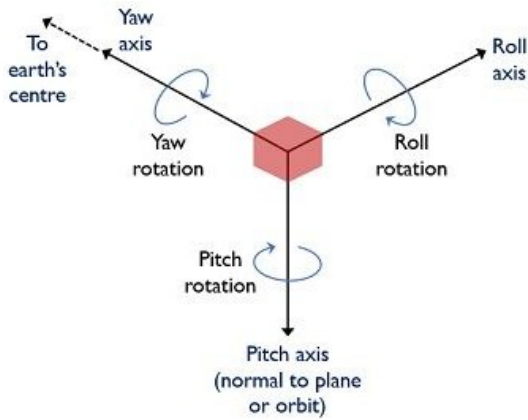

Geostationary satellites are stabilized either by spin stabilization or by the use of momentum wheels inside the satellite. The satellite is set spinning with the spin axis parallel to the N-S axis of the earth. Spin rates are in the range from 50-100rpm. In the absence of the disturbance torques, the spinning satellite would maintain its correct attitude relative to the earth. The disturbance torques can alter the satellite's attitude. Also movement aboard the satellite (like movement experienced by redirecting antennas, and bearing friction) can decrease the spin rate. Corrections must be applied periodically using impulse thrusters or jets.

In case of satellites having solar sails, stabilization is achieved by using momentum wheels inside the satellite. The satellite is stabilized through the gyroscopic effect of spinning wheels.

Satellite station keeping:

A geostationary satellite would drift from its position as a result of disturbing forces. The gravitational field of Moon and Sun causes a drift in the angle of inclination by $0.85^{\circ}/\text{year}$. The drift is cyclic, the angle of inclination is increasing from zero to maximum of 14.67° in 26.6 years, thereafter drifting back to zero inclination again in the same period.

To counter this drift, an oppositely directed velocity component is imparted to the satellite by means of jets, which are pulsed once every 2 or 3 weeks.

Antennas look angles:

Satellite visibility is the ability of a receiver to sense or receive a signal from a **satellite**.

To maximize transmission and reception, the direction of maximum gain of the earth station antenna referred to as antenna "BORE SIGHT" must point directly at the satellite. To align the antenna in this way, two angles must be known. These are "Azimuth" and "Elevation". The Azimuth & Elevation angles are referred to as "**Antenna look angles**".

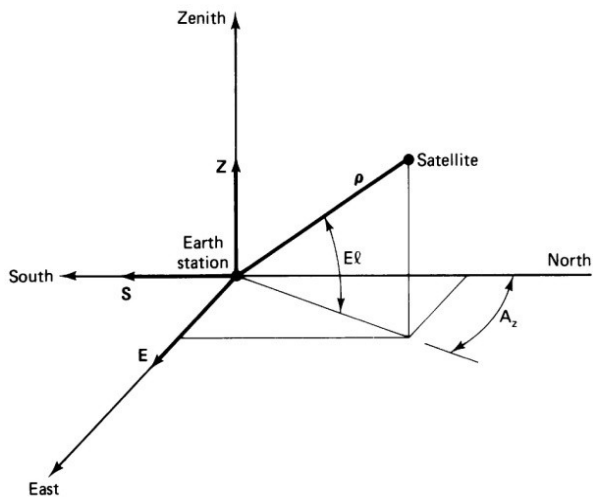

Azimuth angle:

The Azimuth angle A of an earth station is defined as “the angle produced by line of intersection of local horizontal plane and the plane passing through the Earth station, the Satellite and the centre of the earth with the true north”.

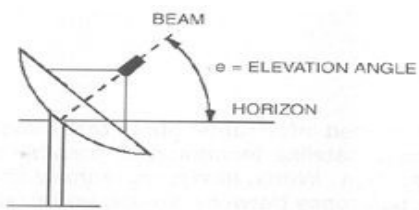

Elevation angle:

The Earth station Elevation angle E is “the angle between the line of intersection of the local horizontal plane and the plane passing through the Earth station, the Satellite and the centre of the Earth and the line joining the Earth station and the Satellite”.

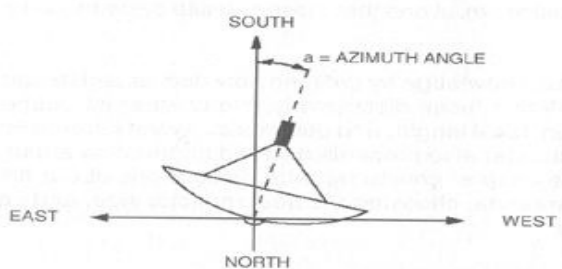

Transponder:

Transponder means transmitter-responder. **It is an equipment channel through the satellite that connects the receiving antenna with the transmitting antenna.** The block diagram of C band transponder channel is as shown below.

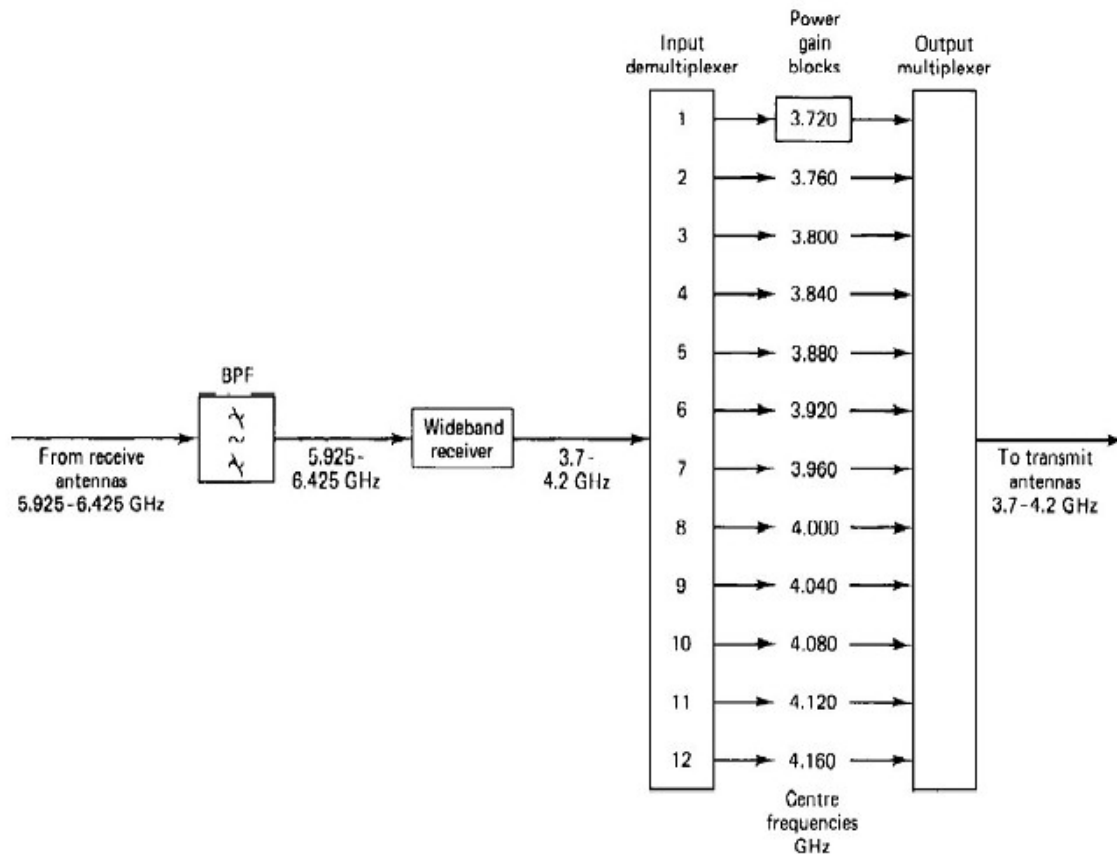

The essential blocks of the transponder are-

- Band pass filter
- Wideband receiver
- Input Demultiplexer
- Power amplifiers
- Output multiplexer

Working:

The bandwidth of the C band transponder is 500MHz corresponding to the input (up-link) frequency range of 5.925 to 6.425 GHz. This input range of signals is passed through a wideband band pass filter. The band pass filter limits the noise and interference of signals.

The output of the band pass filter is given to the wideband receiver. The function of the wide band receiver is to provide the frequency down conversion common to all channels. This also provides the common low noise amplification needed at the input to maintain a satisfactory signal to noise ratio. The output frequency range of the wideband receiver is 3.7 to 4.2 GHz which is the down link frequency band. The overall gain is provided at two sections - one at the input frequency range and other is at output frequency range. As a result the output of the wideband receiver is more stable and prevents oscillations.

Because the wide band receiver is critical to all transponders, a redundant receiver is also provided. This is essentially a backup receiver that is switched on automatically if the other fails.

The output of the wideband receiver is fed to the input of demultiplexer. This section separates the 500 MHz band into separate transponder channel bandwidths. The bandwidth of the transponder channel is 40 MHz including the guard bands.

The output of the each transponder channel is fed to the power amplifiers. These power amplifiers amplify the power that is required to retransmit the signals on the down link.

Once the individual transponder signals have been amplified to the required power levels, they are combined in a multiplexer to form a wideband signal covering the down link frequency range of 3.7 to 4.2 GHz. This wideband signal is radiated by the transmitting antennas.

Block Diagram of Earth Station

The ground station or the Earth station is the terrestrial base of the system. The ground station communicates with the satellite to carry out the designated task

Major subsystems of an Earth station are – transmitter, receiver, antenna and tracking subsystem.

The **block diagram** of earth station is shown in below figure

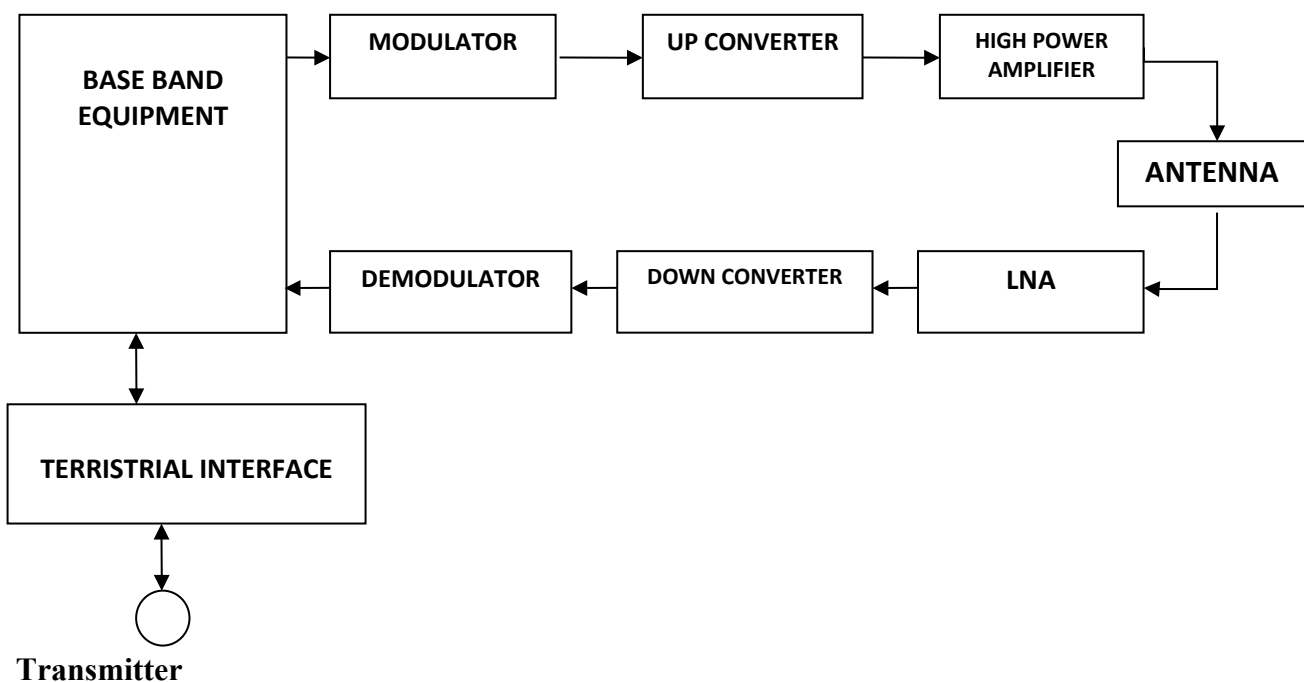

The information enters at base band equipment of earth station from terrestrial network. .

In satellite communication, the appropriate Intermediate Frequency (**IF**) can be chosen. The Up converter performs the frequency conversion of modulated signal to higher frequency. This signal will be amplified by using High power amplifier. The earth station antenna transmits this signal

Earth Station Antenna

The **Earth station Antenna** radiates or receives electromagnetic waves. Since the feed system obeys reciprocity theorem, the earth station antennas are suitable for both transmitting and receiving electromagnetic waves.

Receiver

During **reception**, the earth station antenna receives downlink signal. This is a low-level modulated RF signal. The received signal will be having less signal strength. So, in order to amplify this signal, Low Noise Amplifier (**LNA**) is used. Due to this, there is an improvement in Signal to Noise Ratio (SNR) value.

RF signal can be **down converted** to the Intermediate Frequency (IF) value, because, it is easy to demodulate at these intermediate frequencies.

This information is given to base band equipment for further processing and then delivers to terrestrial network.

Tracking Subsystem

In addition to the above, every earth station has support facilities such as tracking, control and monitoring equipment and power supply. The **Tracking subsystem** keeps track with the satellite and make sure that the beam comes towards it in order to establish the communication

Fiber Optic Communication:

The block diagram of Optical fiber communicationsystem is as shown below. The primary building blocks are

1. Transmitter
2. Receiver
- &
3. OFC

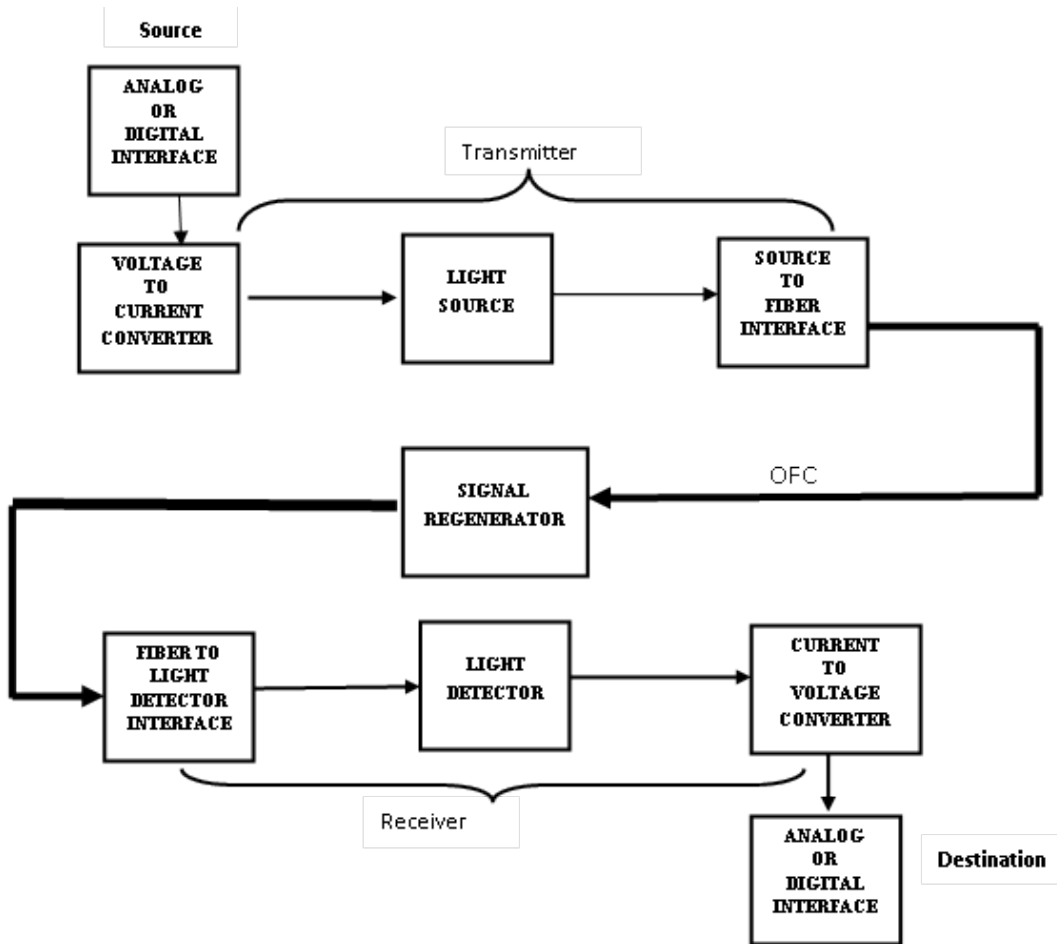

Transmitter:

In the transmitter, light source is modulated by a digital or analog signal. The voltage to current converter acts as an interface between input and light source. The light source is an infrared LED or an Injection Laser diode (ILD). The amount of light emitted by an LED or ILD is proportional to the amount of drive current. The light output by the light source is directly proportional to the magnitude of the input voltage. The source to fiber coupler couples the light emitted by the light source into the optical fiber cable.

Optical Fiber Cable:

The OFC consists of a glass or plastic fiber core surrounded by a cladding. It is encapsulated in a protective jacket. The signal generator provides the light amplification.

Receiver:

The fiber to the light detector couples the light from optical fiber into light detector. The light detector may be PIN diode or APD or a phototransistor. This converts light energy into current. Hence current to voltage converter is required to produce an output voltage proportional to the source information.

The analog or digital interfaces are electrical interfaces that match the impedances and signal levels between the source (input) and destination (output).

Construction:

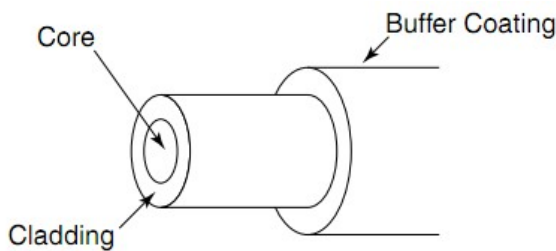

1. The core of a fiber optic cable is made up of a glass or silica . The core is surrounded by cladding, which is made of a comparable substance, such as glass or silica, and has a refractive index lower than the core.
2. The light going along the core undergoes total internal reflection and is thus confined within the core of the optical fiber, even when the cladding has a slightly higher refractive index.
3. A plastic jacket is applied on the outside of the cladding. This is used to shield the optical fiber from damage. Furthermore, optical fibers are frequently bundled together and protected by an outer sheath. This not only adds to the protection but also keeps the optical fibers together.

Propagation mechanism (Working principle):

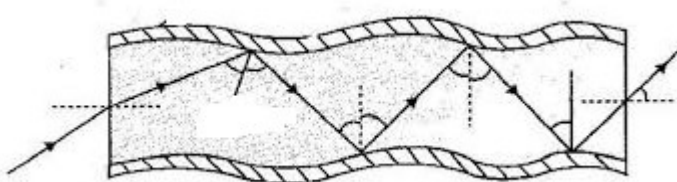

Since light waves can be guided through a fiber it is called light guide. The guiding mechanism can be explained as follows.

In an optical fiber the refractive index of cladding is less than that of core. The light entering the end of the fiber at a slight angle to the axis follows the zigzag path through a series of reflections down the length of the fiber. The total internal reflection at the wall of the fiber can occur only if two conditions are met with.

1. The glass inside the fiber core must have slightly higher refractive index n_1 than the refractive index of cladding n_2 .

2. Light must approach wall with an angle of incidence that is greater than the critical angle.

The reflected ray will leave the fiber wall at the same angle as it struck the wall before reflection.

Derivation for Acceptance angle and Numerical aperture

Consider the light ray propagate in an optical fibre. The incident ray AO enters into core at an angle θ_0 to fibre axis. Let n_1 , n_2 and n_0 be the refractive indices of the core, cladding and surroundings.

